

# Transient Voltage Protection for Stratix GX Devices

## Introduction

This document addresses the phenomenon known as “transient voltage” in a system using Stratix® GX devices. Hot socketing is identified as the major source of transient voltage.

Understanding the source of transient voltage and how to control it can help a designer design a system in which transient voltage does not exceed the recommended voltage.

This document includes the following sections:

- Definitions
- Overview of hot socketing as a common source for transient voltage
- Related physics laws and applying them to hot socketing
- Measurement techniques
- Conclusions & recommendations

## Definitions

This section provides definitions for the terminology used throughout this document.

### *Transient voltage*

Transient voltage is defined as undesired voltage occurring on signal traces when a system is in a transition from one state to another. The occurrence of this voltage beyond the allowed threshold can be destructive. See below for a definition of each state. Transient voltage is short in duration. The industry commonly specifies 20 ns as the duration for this event.

Stratix GX device pins can tolerate a transient voltage of no larger than 3.5 V and not less than -0.5 V for the duration of 20 nanoseconds . However, some designs generate a higher transient voltage, which results in a damaged device. See Table 1 below.

*Table 1: Specification for Stratix GX Transceiver*

Symbol	Conditions	Minimum	Maximum	Units
Receiver input voltage	Commercial and industrial	-0.5 V	3.5V (1)	V

*Note to Table 1*

1. During transitions, the Stratix GX device pins may undershoot to -0.5 V or overshoot to 3.5 V for input currents less than 100mA and periods shorter than 20 ns.
- For further information, see the “Stratix GX Transceiver Block Absolute Maximum Ratings” table in the Stratix GX FPGA Family data sheet.

### *State Definitions*

A system or a component can be in one of the three following states:

The operational state is a steady state in which a component or a system has settled after being transitioned from a non-operational state. In this state, all supplies, in particular ground (GND), are available and stable. The component or system in this state is also referred to as “live.”

The non-operational state is a steady state in which a component or a system has settled after being transitioned from an operational state. In this state, all supplies are *not* available or any residual voltage in the system has been bled out.

The transient state is a temporary state that occurs whenever a component or a system is transitioning from one steady state to another and has unstable supplies, in particular ground (GND). In this temporary state, the voltage on each power rail is undefined.

### *Hot Socketing*

Hot socketing is a common event in which a system or subsystem transitions from one state to another, potentially generating a transient voltage. Hot socketing is the event that generates the most common transient voltage.

Hot socketing allows designers to replace cards, printed circuit boards, cables, and modules in a host system without removing power and without interrupting the host system. Designers can replace a malfunctioning part or to upgrade a system by replacing a part without down time. Hot socketing is also designed for gradual expansion of a system without removing power. If implemented properly, a hot socketing solution creates a highly reliable system.

In this section, a hot socketing system is defined as a system that contains a backplane and one or more added linecards. This section also assumes that the backplane is powered at all times.

Applications using hot socketing designs include telecom systems, servers, RAID, Hot Plug PCI, CompactPCI, and USB.

- Hot socketing, hot swap, hot plug, and hot dock are used interchangeably to name a major transient state. This document uses the term “hot socketing.”

Figure 1 illustrates an operational and non-operational backplane and linecards. Figure 2 shows an example of an actual backplane and linecard system.

Figure 1. Backplane & Linecard Placement

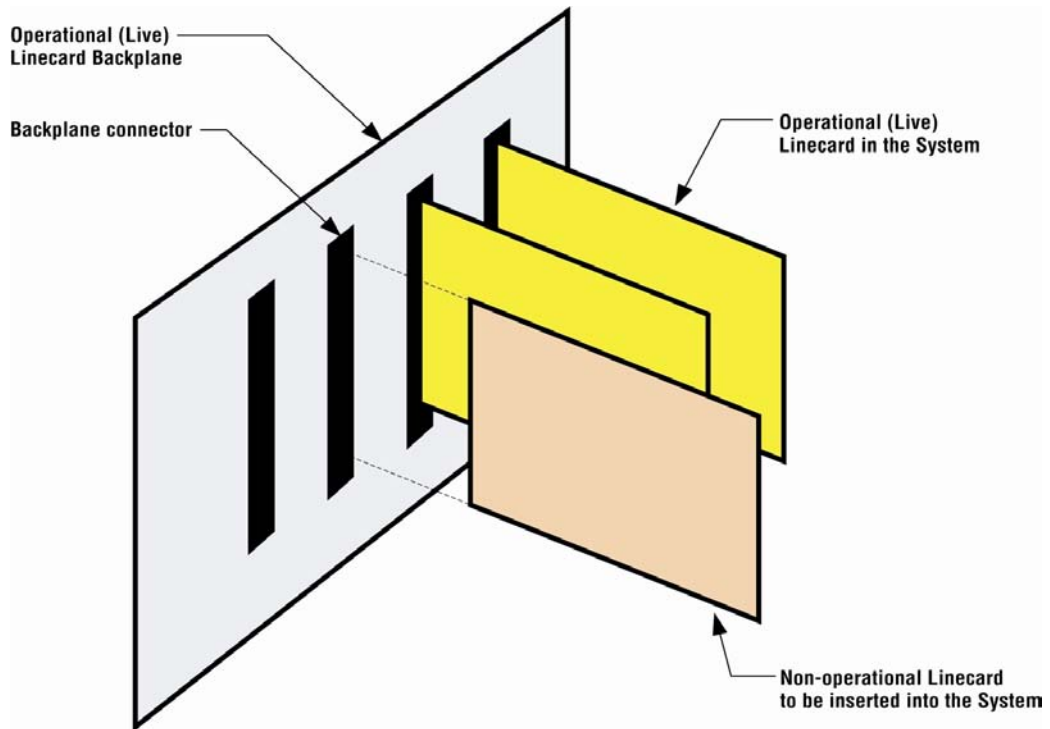

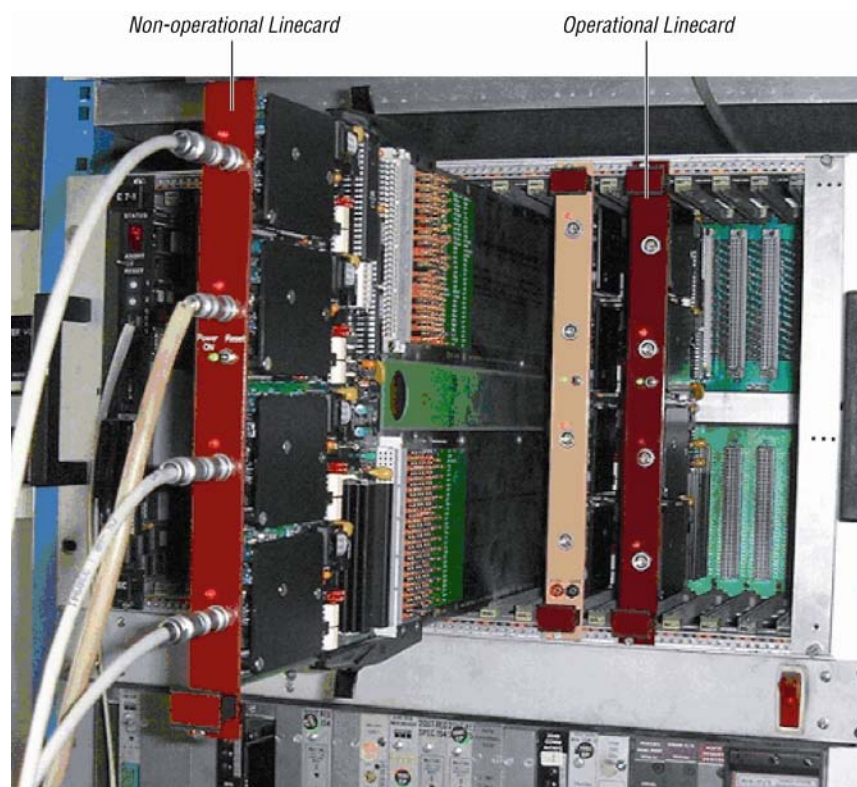
*Figure 2. Sample Backplane & Linecard*

## The Hot Socketing Event

In order to understand what happens in a system during a hot socketing event, it is important to understand the status of the system before and during an event.

Before an event, the backplane is operational (live). In a live system, all bulk and bypass capacitors are fully charged and all powers and GND planes are stable. On the linecard, all power and GND planes are at an unknown voltage.

During an event, inserting an uncharged linecard into the live system mates the stable planes with the unstable ones on the linecard. This quickly charges the card and discharges the live backplane, generating a surge of energy.

- It is important to understand that, since most of the insertions are completed manually (from the very first galvanized contact to the final mating), the card might be rocked and contact is applied on and off. While hot socketing, the card can bounce a few times, and in each bounce, a surge of energy is created. Mating an uncharged linecard creates a large rush of current (or surge current) from the live backplane to the uncharged linecard.

## The physics of surge currents and applying them to hot socketing

Using the Laws of Ampere and Faraday, the following section lays the physical foundation for the understanding of the transient voltage effect and describes current surges and the resulting transient voltage. We will not dig into the fine details of each one of those laws, but rather try to use an intuitive explanation.

### *Ampere's & Faraday's Laws*

Ampere's Law states that a current through a looped conductor generates a magnetic field. If this current is changing with time ( $di/dt$ ), the flux of the magnetic field, through the area shaped by that line, changes with time as well ( $d\Phi/dt$ ).

Faraday's Law states that a voltage emerges between the edges of any static, looped, or conductive line that is experiencing a changing magnetic flux, through the area it shapes.

Figure 3 below illustrates these two laws. The switch on the aggressor loop in Figure 3 is an example of applying a charge for a short duration, then detaching the charge. This cycle of toggling the switch on and off generates pulses, each with current changing in time ( $di/dt$ ).

*Figure 3. Ampere's & Faraday's Laws*

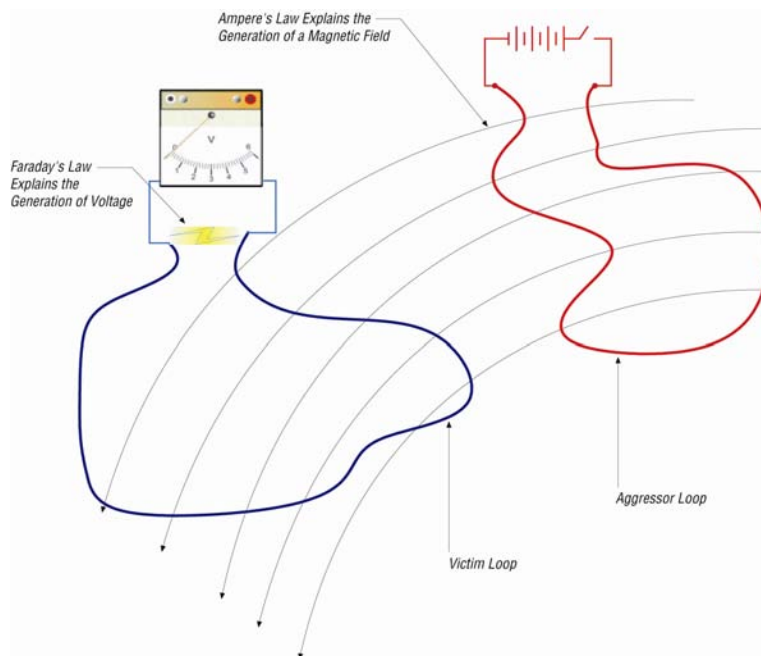

### *Applying Physics to Hot Socketing*

A hot socketing event produces a surge current, or a series of surge currents (if we take into account the bouncing and rocking of the linecard while inserting it to the system). The current is generated due to the mating process of a non-operational linecard to an operational (live) charged backplane.

The first mating of the linecard and the backplane is equivalent to closing the switch, as shown in Figure 3, above. At the very first moment, a surge current pulse is generated on the power traces, changing from 0 to a peak value, forming a rapid  $di/dt$ .

The looped area is shaped between the power (either trace, via, or plane) and the lowest potential in the system at that time. In figure 4, the linecard's GND is assumed to be already stable.

These loops are shaped both on the backplane and on the linecard (Figure 4 shows only the part of the loop that is on the linecard). By applying Ampere's Law, each current pulse generates a time-variant magnetic flux through the area shaped by the power and its corresponding GND.

Other conductive traces (mostly signal traces) form a looped area referenced to GND, in the same manner described above for the power. The changing magnetic field, generated by the current surge on the power (obeying Ampere's Law), propagates and generates a voltage spike at the end of any signal trace in its way (obeying Faraday's Law).

Although the mating card (linecard) has GND planes, if there is a poor connection or no connection between any GND plane on the linecard and the backplane's GND, they might not act as GND in the essence of the lowest potential. In this case, the loop shapes in reference to a different lower potential than the linecard's GND. When a good connection exists, then the loop area is shaped in reference to the linecard's GND.

- The key conclusion is that applying GND to a linecard as the first mating contact allows better predictability of a possible loop in the system.

Figure 4 illustrates an optional linecard based on the Stratix GX device.

Figure 4. Optional Linecard

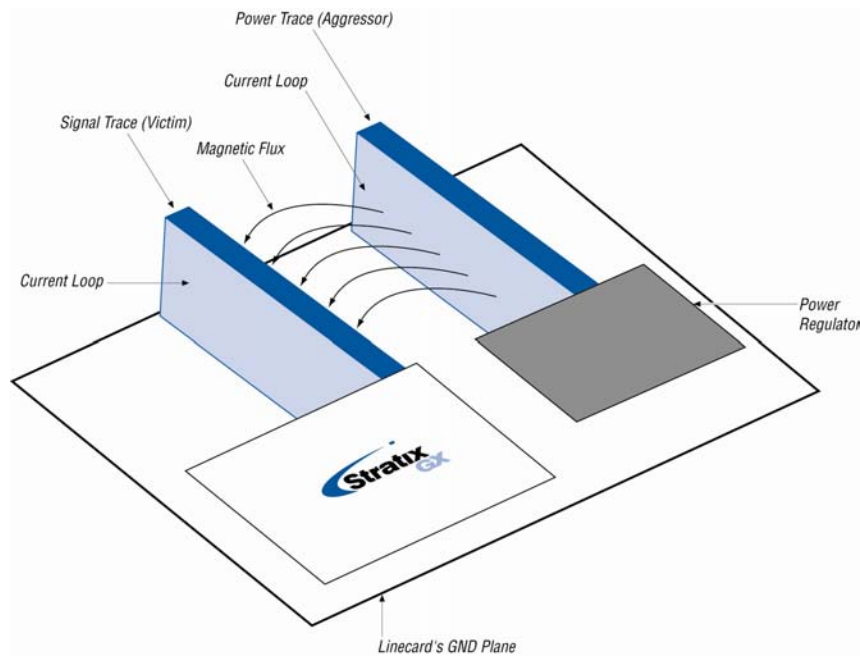

## Transient Voltage Effects on Stratix GX Devices

The previous section covers the most common source for a transient voltage, hot socketing, linking physics and a hot socketing event.

This section discusses the effect of transient voltage and how it can influence a device, in particular Stratix GX device RX pins. Devices are designed to work in an operational state, where all supplies are within the tolerances from the nominal values.

Common practice in I/O cell design takes into account some variations from nominal values. Various mechanisms are designed as part of the silicon, to cope with a sudden transient voltage. ESD is one example.

As mentioned previously, Stratix GX device RX pins are designed to cope with a transient voltage magnitude of not larger than 3.5 V or lower than -0.5 V, for a duration of 20 nanoseconds, between the RX input pin and the corresponding GND, as shown in Figure 5.

Figure 5. Transient Voltage

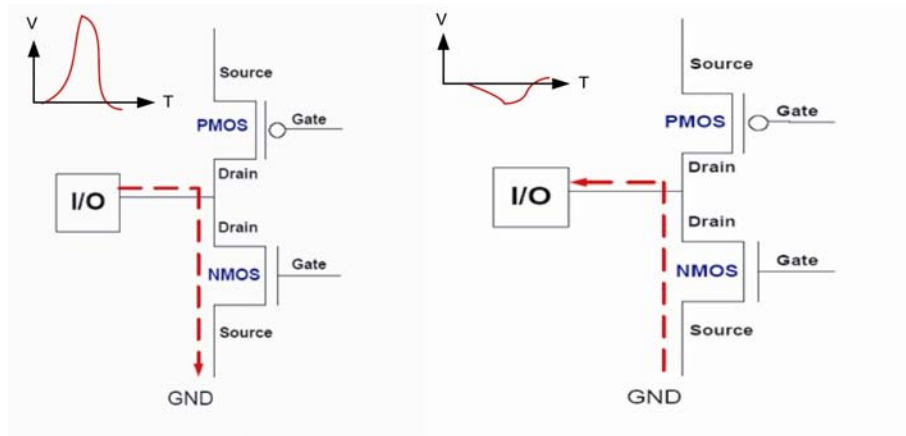

## Measurements

This section discusses the key elements of a successful measurement of transient voltage that is correlated to the real event. See Figure 6 for an example.

1. **Measure as close as possible to the target.** In a backplane/linecard system, the measurement is taken on the linecard. For measuring the transient voltage on Stratix GX device RX pins, place the probe as close as possible to those pins. Use the vias associated with the device as the first choice. Try to solder the probe for a better physical contact. While hot socketing, the vibrations might move the probe and, as a result, a wrong measurement might be taken. Therefore, mechanical stability of the probe is important.
2. **Measure between the Stratix GX device's RX pin and corresponding GND.** Use the nearest available GND (a GND via for example). The probe wires shape a looped area, potentially allowing a transient voltage to develop on the probe lines resulting in a wrong reading.
  - If there is more than one GND plane, the Stratix GX device's corresponding GND refers to the GND plane to which the device is connected. For example, if there are two GND planes, chassis GND and digital GND, and the device is connected to the digital GND, the Stratix GX device's corresponding GND refers to the digital GND.
3. **Use a differential probe.** A regular probe will introduce the oscilloscope's GND, which changes the GND scheme. A differential probe will prevent this.

Figure 6. Measurement Results

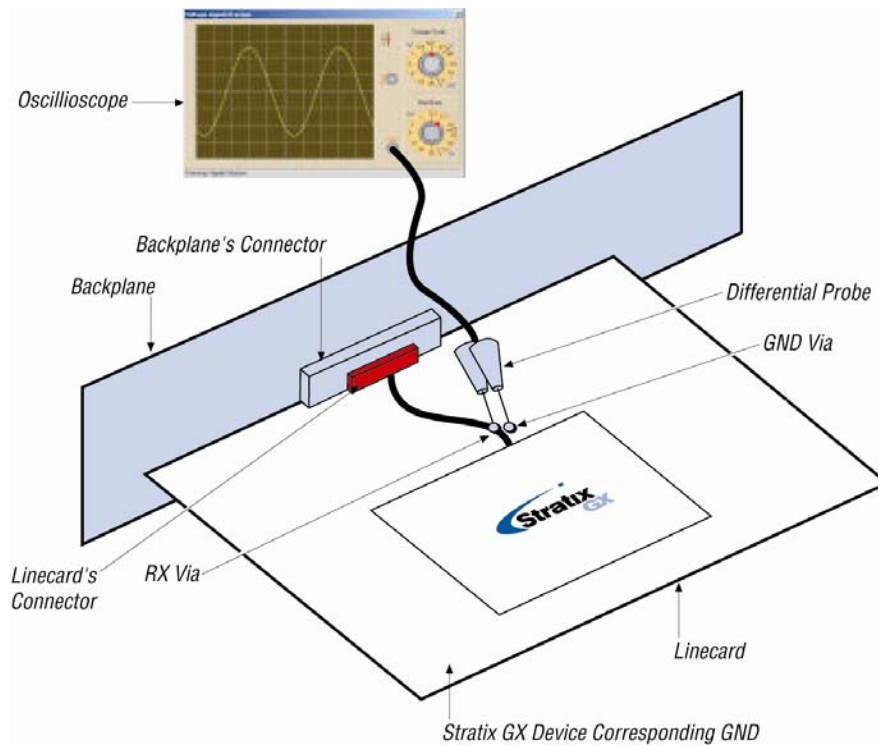

## Conclusion

Mating a live system and an uncharged subsystem generates a surge current on the power lines. This surge current generates a time-varying magnetic field that generates a momentary voltage on victim lines. We refer to this voltage as the transient voltage.

The magnitude of the surge current has a relation to the following:

- **The supply voltage.** There is a direct relation between the magnitude of the transient voltage and the supply voltage. If a spike occurs in a system using 48 V, it will have greater transient voltage amplitude than in a system with 3.3 V.
- **The area the loop shapes.** There is a direct relation between the magnitude of the transient voltage and the loop. For example, a long cable or a long trace on a backplane will form a larger loop.
- **The load introduced at the mating.** There is a reverse relation between the magnitude of the transient voltage and the impedance. Some systems are designed so that at the very moment of the mating the power lines see very high impedance, so the surge current will be lower.

Applying GND before applying power is another important preventative measure. This guarantees the following:

- **Better protection for sensitive devices such as silicon.** Devices need to be referenced to proper GND to perform as expected. Missing or insufficient GND alters the functionality of protection mechanisms, preventing them from protecting the silicon.

- **More stable state.** Allows a more stable state for any device in the system by ensuring at least the lowest potential (GND).
- **Smaller and controlled loops.** If GND is not stable, shielding, guarding, and GND planes will not work as planned. The magnetic fields propagate beyond what is planned for in the design.

## Recommendations for Hot Socketing

Any design should minimize the length of power traces, in particular those applications where the power is applied as discussed in this document.

It is recommended that you apply the linecard's GND first, a simple mechanical solution, where the GND pins are longer.

- Note that when you hot socket a cable, the first element that mates is the connector shielding.

In some telecom systems where the supplies are driven from a -48V source, the following conditions exist:

- The supply's lowest potential is known as return (RTN). It may or may not reference to GND.
- Due to the high voltage potential, any surge current that is a result of hot socketing will have a sufficiently large magnitude.
- The power supply's highest potential can go as high as 72 volts (when referenced to its lowest potential or return).

In these designs, it is imperative that GND:

- Is sufficient both for AC and DC currents
- Be supplied prior to the -48V

If the Stratix GX device transceiver lines run through a backplane or a cable, verify no power runs near the signal lines. If you use a cable for the signals, you must:

- Use a separate cable for powers and signals.
- or*
- The power design must assure that the power bring-up is done via a dedicated power controller (slow start circuit) to prevent rush currents (less preferred than the former).

In a backplane and on the edge connector you must do the following:

- Avoid assigning power lines close to a signal line.
- Shield power lines with sufficient GND shielding.

Place all voltage regulators as close as possible to the backplane. Use power controller, which will gradually power the linecard, minimizing the surge current.



101 Innovation Drive  
San Jose, CA 95134  
(408) 544-7000  
[www.altera.com](http://www.altera.com)

Copyright © 2005 Altera Corporation. All rights reserved. Altera, The Programmable Solutions Company, the stylized Altera logo, specific device designations, and all other words and logos that are identified as trademarks and/or service marks are, unless noted otherwise, the trademarks and service marks of Altera Corporation in the U.S. and other countries.\* All other product or service names are the property of their respective holders. Altera products are protected under numerous U.S. and foreign patents and pending applications, maskwork rights, and copyrights. Altera warrants performance of its semiconductor products to current specifications in accordance with Altera's standard warranty, but reserves the right to make changes to any products and services at any time without notice. Altera assumes no responsibility or liability arising out of the application or use of any information, product, or service described herein except as expressly agreed to in writing by Altera Corporation. Altera customers are advised to obtain the latest version of device specifications before relying on any published information and before placing orders for products or services.