

Adapt easily to market changes

“Our customers expect our products to not only stay in production for several years but also to adapt to changing requirements. Programmable solutions from Altera give us the flexibility to meet customer expectations while also controlling our development costs.”

—Hans Wimmer, Managing Director, Bernecker & Rainer Industrie Elektronik GmbH

Design for today and tomorrow

From programmable logic controllers (PLCs) to drives and industrial networks, your industrial applications help automate our world. To keep all of the critical parts moving, your products have to be reliable, adaptable, and built to last. At the same time, business success requires you to both act quickly and drive down costs.

With innovative programmable solutions from Altera at the heart of your industrial designs, you’re equipped to tackle the most difficult challenges:

- Adapting quickly to end market changes
- Consistently achieving first-mover advantage
- Making cost-saving design reuse a normal part of your development process
- Creating products that are virtually obsolescence-proof

Altera® programmable solutions were developed to deliver high performance, reprogrammability, and interoperability — key capabilities for an industrial design environment. These solutions work with a variety of intellectual property (IP) cores that enable support for industry standards such as EtherCAT, PROFINET, and SERCOS III.

Altera programmable solutions in a factory environment

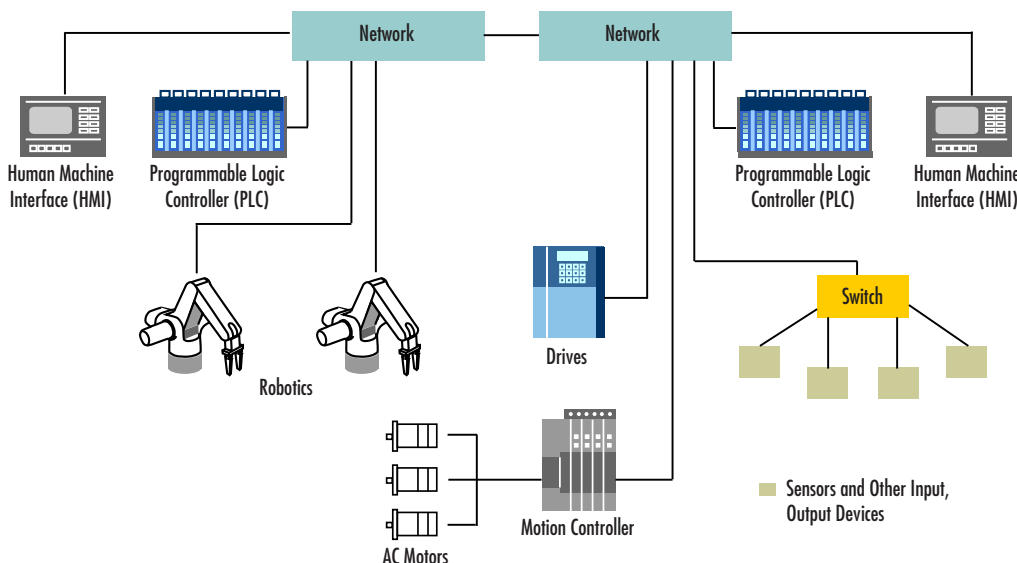

In any given automated factory environment, programmable logic devices can play a key role in running a variety of systems. Altera’s programmable solutions provide a flexible, obsolescence-proof design foundation for products ranging from PLCs to HMIs.

How Altera can help

Whether your products help build cars or perform electronic point-of-sales transactions, your customers will expect them to have long lifecycles. After all, stopping a production line or interrupting 24/7 service simply isn't cost effective. Our programmable logic devices (PLDs) are geared to support long lifecycles and even future-proofing. Because they are reprogrammable, you can support changing standards and evolving customer expectations. You can even reuse your designs across multiple projects, saving time, engineering resources, and money.

Compared to ASICs, with their extensive NRE costs and minimum ordering quantities, Altera PLDs can help lower your total cost of ownership as well as your development risks. Because multiple ASSP, CPU, and hard macro functions can be integrated into an FPGA, you can cost-effectively differentiate and optimize your products. You can even base multiple products on a single hardware platform. With our Nios® II embedded processors integrated into Cyclone® low-cost FPGAs, you can meet both your price-sensitive and compute-intensive design requirements. In short, Altera PLDs offer a flexible and obsolescence-proof design path that is also easy on your budget.

Altera programmable solutions

Product	Benefits
Stratix® FPGA series	High performance, high density, low power consumption, high memory bandwidth, signal integrity
Cyclone FPGA series	Industry-leading performance at low cost, with dedicated DSP circuitry
MAX® CPLD series	Low cost, low power, instant-on, and non-volatile single chip solution
Nios II embedded processors	Customizable feature set, costs, and performance that can be tailored to exact system requirements, no risk of processor and ASSP obsolescence

What else is on your mind?

I've always thought that FPGAs are expensive and slow compared to processors.

Today's FPGAs are a very cost-effective, high-performance technology. They allow you to integrate many components on to a single device, reducing board area and component costs. Even the lowest-cost Cyclone FPGA family delivers high-speed parallel processing with multipliers and internal memory that run at 250 MHz and interfaces like LVDS, PCI Express, and fast external memories. An example of the impact on your R&D budget: you can run a Nios II processor in a Cyclone II FPGA using as little as 35 cents in logic.

Can Altera PLDs support industrial temperatures?

Yes, Altera industrial-grade devices are specified at -40°C to +100°C junction temperature range. Our devices are designed to perform well under extreme temperature conditions, and have been thoroughly characterized. Certain devices are even available with a wider temperature range (-40°C to 105°C junction).

I'm new to FPGAs — how can I learn more?

Altera provides an array of online and instructor-led training classes to help with FPGA development. Offerings include introductory courses on Quartus® II design software, SOPC Builder system integration tool, and Nios II embedded processor. Find out more at www.altera.com/training.

Want to dig deeper?

To start designing with Altera programmable solutions, or to learn more about our technology and resources, contact your local Altera sales representative or log on to www.altera.com/industrial.

Altera Corporation

101 Innovation Drive
San Jose, CA 95134
USA
Telephone: (408) 544-7000
www.altera.com

Altera European Headquarters

Holmers Farm Way
High Wycombe
Buckinghamshire
HP12 4XF
United Kingdom
Telephone: (44) 1 94 602 000

Altera Japan Ltd.

Shinjuku i-Land Tower 32F
6-5-1, Nishi-Shinjuku
Shinjuku-ku, Tokyo 163-1332
Japan
Telephone: (81) 3 3340 9480
www.altera.co.jp

Altera International Ltd.

2102 Tower 6
The Gateway, Harbour City
9 Canton Road
Tsimshatsui Kowloon
Hong Kong
Telephone: (852) 2945 7000

