

The Quartus II Logic Analyzer Interface (LAI) allows you to use an external logic analyzer and a minimal number of Altera-supported device I/O pins to examine the behavior of internal signals while your design is running at full speed on your Altera®- supported device.

The LAI connects a large set of internal device signals to a small number of output pins. You can connect these output pins to an external logic analyzer for debugging purposes. In the Quartus II LAI, the internal signals are grouped together, distributed to a user-configurable multiplexer, and then output to available I/O pins on your Altera-supported device. Instead of having a one-to-one relationship between internal signals and output pins, the Quartus II LAI enables you to map many internal signals to a smaller number of output pins. The exact number of internal signals that you can map to an output pin varies based on the multiplexer settings in the Quartus II LAI.

This chapter details the following topics:

- “Choosing a Logic Analyzer”
- “Debugging Your Design Using the LAI” on page 14–4
- “Working with LAI Files” on page 14–4
- “Controlling the Active Bank During Runtime” on page 14–7
- “Using the LAI with Incremental Compilation” on page 14–7



The term “logic analyzer” when used in this chapter includes both logic analyzers and oscilloscopes equipped with digital channels, commonly referred to as mixed signal analyzers or MSOs.

- ❓ Refer to *Devices and Adapters* in Quartus II Help for a list of Altera-supported devices.

## Choosing a Logic Analyzer

The Quartus II software offers the following two general purpose on-chip debugging tools for debugging a large set of RTL signals from your design:

- The SignalTap® II Logic Analyzer
- An external logic analyzer, which connects to internal signals in your Altera-supported device by using the Quartus II LAI

Table 14-1 describes the advantages of each debugging tool.

**Table 14-1. Comparing the SignalTap II Logic Analyzer with the Logic Analyzer Interface**

Feature and Description	Logic Analyzer Interface	SignalTap II Logic Analyzer
<b>Sample Depth</b> You have access to a wider sample depth with an external logic analyzer. In the SignalTap II Logic Analyzer, the maximum sample depth is set to 128 Kb, which is a device constraint. However, with an external logic analyzer, there are no device constraints, providing you a wider sample depth.	✓	—
<b>Debugging Timing Issues</b> Using an external logic analyzer provides you with access to a “timing” mode, which enables you to debug combined streams of data.	✓	—
<b>Performance</b> You frequently have limited routing resources available to place and route when you use the SignalTap II Logic Analyzer with your design. An external logic analyzer adds minimal logic, which removes resource limits on place-and-route.	✓	—
<b>Triggering Capability</b> The SignalTap II Logic Analyzer offers triggering capabilities that are comparable to external logic analyzers.	✓	✓
<b>Use of Output Pins</b> Using the SignalTap II Logic Analyzer, no additional output pins are required. Using an external logic analyzer requires the use of additional output pins.	—	✓
<b>Acquisition Speed</b> With the SignalTap II Logic Analyzer, you can acquire data at speeds of over 200 MHz. You can achieve the same acquisition speeds with an external logic analyzer; however, you must consider signal integrity issues.	—	✓

 The Quartus II software offers a portfolio of on-chip debugging tools. For an overview and comparison of all tools available in the Quartus II software on-chip debugging tool suite, refer to *Section V. In-System Debugging* in volume 3 of the *Quartus II Handbook*.

## Required Components

You must have the following components to perform analysis using the Quartus II LAI:

- The Quartus II software starting with version 5.1 and later
- The device under test
- An external logic analyzer
- An Altera communications cable
- A cable to connect the Altera-supported device to the external logic analyzer

Figure 14-1 shows the LAI and the hardware setup.

**Figure 14-1. LAI and Hardware Setup**

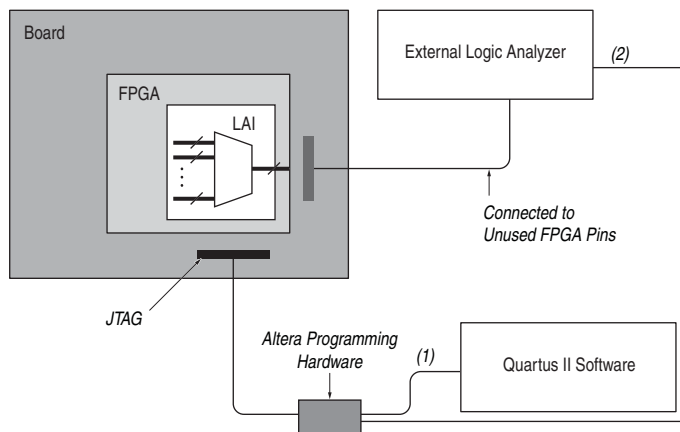

**Notes to Figure 14-1:**

- (1) Configuration and control of the LAI using a computer loaded with the Quartus II software via the JTAG port.
- (2) Configuration and control of the LAI using a third-party vendor logic analyzer via the JTAG port. Support varies by vendor.

## Debugging Your Design Using the LAI

Figure 14-2 shows the steps you must follow to debug your design with the Quartus II LAI.

**Figure 14-2. LAI and Hardware Setup**

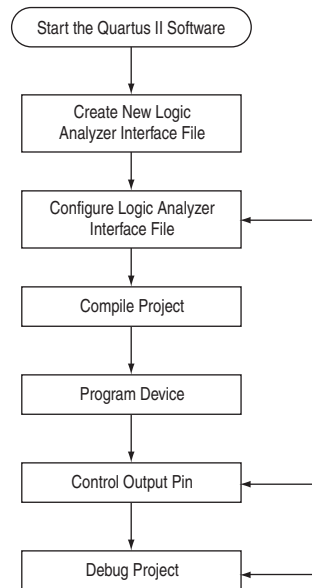

**Notes to Figure 14-1:**

- (1) Configuration and control of the LAI using a computer loaded with the Quartus II software via the JTAG port.
- (2) Configuration and control of the LAI using a third-party vendor logic analyzer via the JTAG port. Support varies by vendor.

## Working with LAI Files

The **.lai** file stores the configuration of an LAI instance. The **.lai** file opens in the LAI editor. The editor allows you to group multiple internal signals to a set of external pins. The configuration parameters are described in the following sections.

- ① To create a new **.lai** file or open an existing **.lai** file, refer to *Setting Up the Logic Analyzer Interface* in Quartus II Help.

## Configuring the File Core Parameters

After you create the .lai file, you must configure the .lai file core parameters by clicking on the **Setup View** list, and then selecting **Core Parameters**. Table 14-2 lists the .lai file core parameters.

**Table 14-2. LAI File Core Parameters**

Parameter	Description
Pin Count	The Pin Count parameter signifies the number of pins you want dedicated to your LAI. The pins must be connected to a debug header on your board. Within the Altera-supported device, each pin is mapped to a user-configurable number of internal signals. The Pin Count parameter can range from 1 to 255 pins.
Bank Count	The Bank Count parameter signifies the number of internal signals that you want to map to each pin. For example, a Bank Count of 8 implies that you will connect eight internal signals to each pin. The Bank Count parameter can range from 1 to 255 banks.
Output/Capture Mode	The Output/Capture Mode parameter signifies the type of acquisition you perform. There are two options that you can select: <b>Combinational/Timing</b> —This acquisition uses your external logic analyzer’s internal clock to determine when to sample data. Because Combinational/Timing acquisition samples data asynchronously to your Altera-supported device, you must determine the sample frequency you should use to debug and verify your system. This mode is effective if you want to measure timing information, such as channel-to-channel skew. For more information about the sampling frequency and the speeds at which it can run, refer to the data sheet for your external logic analyzer. <b>Registered/State</b> —This acquisition uses a signal from your system under test to determine when to sample. Because Registered/State acquisition samples data synchronously with your Altera-supported device, it provides you with a functional view of your Altera-supported device while it is running. This mode is effective when you verify the functionality of your design.
Clock	The Clock parameter is available only when Output/Capture Mode is set to Registered State. You must specify the sample clock in the Core Parameters view. The sample clock can be any signal in your design. However, for best results, Altera recommends that you use a clock with an operating frequency fast enough to sample the data you would like to acquire.
Power-Up State	The Power-Up State parameter specifies the power-up state of the pins you have designated for use with the LAI. You have the option of selecting tri-stated for all pins, or selecting a particular bank that you have enabled.

## Mapping the LAI File Pins to Available I/O Pins

To configure the .lai file I/O pin parameters, select **Pins** in the **Setup View** list. To assign pin locations for the LAI, double-click the **Location** column next to the reserved pins in the **Name** column, and the Pin Planner opens.



For information about how to use the Pin Planner, refer to the *Pin Planner* section in the *I/O Management* chapter in volume 2 of the *Quartus II Handbook*.

## Mapping Internal Signals to the LAI Banks

After you have specified the number of banks to use in the **Core Parameters** settings page, you must assign internal signals for each bank in the LAI. Click the **Setup View** arrow and select **Bank n** or **All Banks**.

To view all of your bank connections, click **Setup View** and select **All Banks**.

## Using the Node Finder

Before making bank assignments, on the View menu, point to **Utility Windows** and click **Node Finder**. Find the signals that you want to acquire, then drag and drop the signals from the **Node Finder** dialog box into the bank **Setup View**. When adding signals, use **SignalTap II: pre-synthesis** for non-incrementally routed instances and **SignalTap II: post-fitting** for incrementally routed instances.

As you continue to make assignments in the bank **Setup View**, the schematic of your LAI in the **Logical View** of your .lai file begins to reflect your assignments. Continue making assignments for each bank in the **Setup View** until you have added all of the internal signals for which you wish to acquire data.

## Compiling Your Quartus II Project

When you save your .lai file, a dialog box prompts you to enable the LAI instance for the active project. Alternatively, you can specify the .lai file your project uses in the **Global Project Settings** dialog box.

After you specify the name of your .lai file, you must compile your project. To compile your project, on the Processing menu, click **Start Compilation**.

To ensure that the LAI is properly compiled with your project, expand the entity hierarchy in the Project Navigator. (To display the Project Navigator, on the View menu, point to **Utility Windows** and click **Project Navigator**.) If the LAI is compiled with your design, the sld\_hub and sld\_multitap entities are shown in the project navigator (Figure 14-3).

**Figure 14-3. Project Navigator**

Entity	Logic Cells	LC Registers
Stratix: EP1S10B672C7		
test	136 (1)	81
sld_multitap:auto_lai_0	35 (11)	15
sld_hub:sld_hub_inst	100 (25)	65

## Programming Your Altera-Supported Device Using the LAI

After compilation completes, you must configure your Altera-supported device before using the LAI.

You can use the LAI with multiple devices in your JTAG chain. Your JTAG chain can also consist of devices that do not support the LAI or non-Altera, JTAG-compliant devices. To use the LAI in more than one Altera-supported device, create an .lai file and configure an .lai file for each Altera-supported device that you want to analyze.

- ❓ To configure a device or a set of devices for use with LAI, refer to *Enabling the Logic Analyzer Interface* in Quartus II Help.

## Controlling the Active Bank During Runtime

When you have programmed your Altera-supported device, you can control which bank you map to the reserved .jai file output pins. To control which bank you map, in the schematic in the logical view, right-click the bank and click **Connect Bank** (Figure 14-4).

Figure 14-4. Configuring Banks

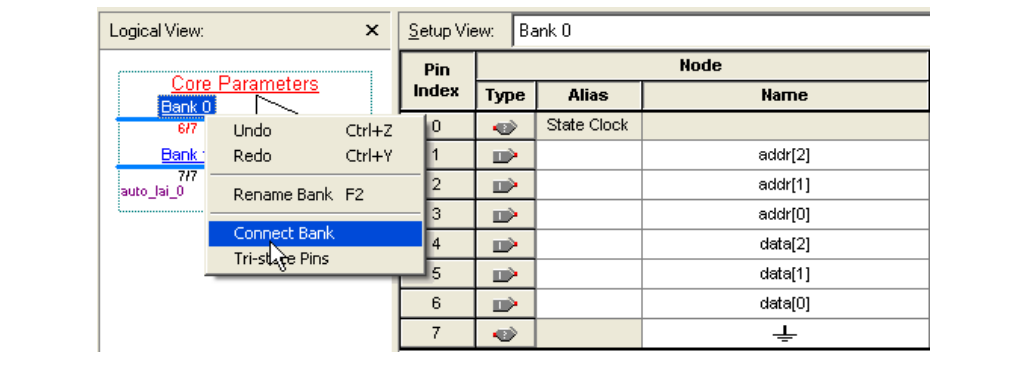

## Acquiring Data on Your Logic Analyzer

To acquire data on your logic analyzer, you must establish a connection between your device and the external logic analyzer.

- For more information about this process and for guidelines about how to establish connections between debugging headers and logic analyzers, refer to the documentation for your logic analyzer.

## Using the LAI with Incremental Compilation

The Incremental Compilation feature in the Quartus II software allows you to preserve the synthesis and fitting results of your design. This is an effective feature for reducing compilation times if you only modify a portion of a design or you wish to preserve the optimization results from a previous compilation.

The Incremental Compilation feature is well suited for use with LAI since LAI comprises a small portion of most designs. Because LAI consists of only a small portion of your design, incremental compilation helps to minimize your compilation time. Incremental compilation works best when you are only changing a small portion of your design. Incremental compilation yields an accurate representation of your design behavior when changing the .jai file through multiple compilations.

- For further details on how to use Incremental Compilation with the LAI, refer to *Enabling the Logic Analyzer Interface* in Quartus II Help.

## Conclusion

As the device industry continues to make technological advancements, outdated debugging methodologies must be replaced with new technologies that maximize productivity. The LAI feature enables you to connect many internal signals within your Altera-supported device to an external logic analyzer with the use of a small number of I/O pins. This new technology in the Quartus II software enables you to use feature-rich external logic analyzers to debug your Altera-supported device design, ultimately enabling you to deliver your product in the shortest amount of time.

## Document Revision History

Table 14-3 shows the revision history for this chapter.

**Table 14-3. Document Revision History**

Date	Version	Changes
November 2011	10.1.1	<ul style="list-style-type: none"> <li>■ Changed to new document template</li> </ul>
December 2010	10.1.0	<ul style="list-style-type: none"> <li>■ Minor editorial updates</li> <li>■ Changed to new document template</li> </ul>
August 2010	10.0.1	Corrected links
July 2010	10.0.0	<ul style="list-style-type: none"> <li>■ Created links to the Quartus II Help</li> <li>■ Editorial updates</li> <li>■ Removed Referenced Documents section</li> </ul>
November 2009	9.1.0	<ul style="list-style-type: none"> <li>■ Removed references to APEX devices</li> <li>■ Editorial updates</li> </ul>
March 2009	9.0.0	<ul style="list-style-type: none"> <li>■ Minor editorial updates</li> <li>■ Removed Figures 15-4, 15-5, and 15-11 from 8.1 version</li> </ul>
November 2008	8.1.0	Changed to 8-1/2 x 11 page size. No change to content
May 2008	8.0.0	<ul style="list-style-type: none"> <li>■ Updated device support list on page 15-3</li> <li>■ Added links to referenced documents throughout the chapter</li> <li>■ Added "Referenced Documents"</li> <li>■ Added reference to <i>Section V. In-System Debugging</i></li> <li>■ Minor editorial updates</li> </ul>

 For previous versions of the *Quartus II Handbook*, refer to the [Quartus II Handbook Archive](#).

 Take an [online survey](#) to provide feedback about this handbook chapter.