

This chapter describes guidelines for implementing dual unbuffered DIMM (UDIMM) DDR2 and DDR3 SDRAM interfaces. This chapter discusses the impact on signal integrity of the data signal with the following conditions in a dual-DIMM configuration:

- Populating just one slot versus populating both slots
- Populating slot 1 versus slot 2 when only one DIMM is used
- On-die termination (ODT) setting of 75  $\Omega$  versus an ODT setting of 150  $\Omega$

For detailed information about a single-DIMM DDR2 SDRAM interface, refer to the *DDR2 and DDR3 SDRAM Board Design Guidelines* chapter.

## DDR2 SDRAM

This section describes guidelines for implementing a dual slot unbuffered DDR2 SDRAM interface, operating at up to 400-MHz and 800-Mbps data rates. [Figure 5-1](#) shows a typical DQS, DQ, and DM signal topology for a dual-DIMM interface configuration using the ODT feature of the DDR2 SDRAM components.

**Figure 5-1. Dual-DIMM DDR2 SDRAM Interface Configuration (1)**

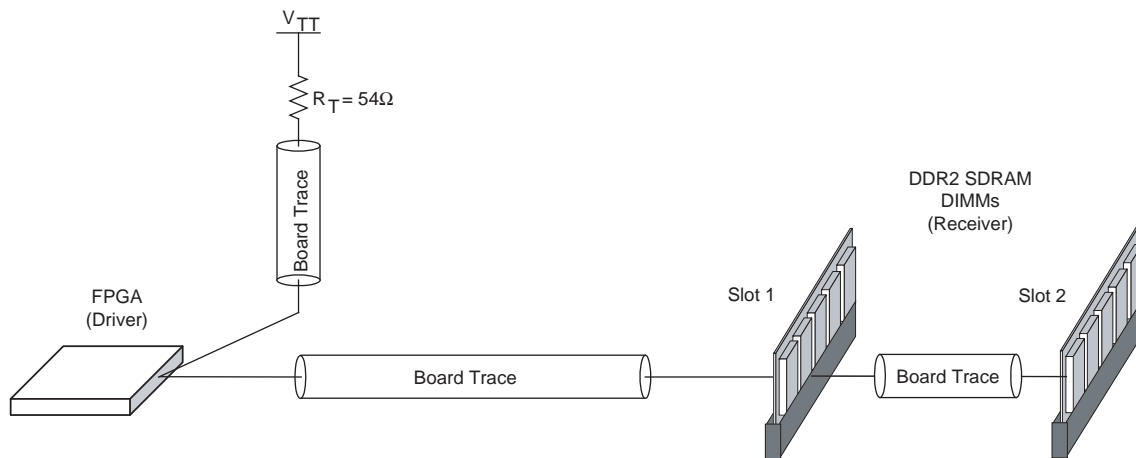

**Note to Figure 5-1:**

(1) The parallel termination resistor  $R_T = 54 \Omega$  to  $V_{TT}$  at the FPGA end of the line is optional for devices that support dynamic on-chip termination (OCT).

© 2011 Altera Corporation. All rights reserved. ALTERA, ARRIA, CYCLONE, HARDCOPY, MAX, MEGACORE, NIOS, QUARTUS and STRATIX words and logos are trademarks of Altera Corporation and registered in the U.S. Patent and Trademark Office and in other countries. All other words and logos identified as trademarks or service marks are the property of their respective holders as described at [www.altera.com/common/legal.html](http://www.altera.com/common/legal.html). Altera warrants performance of its semiconductor products to current specifications in accordance with Altera's standard warranty, but reserves the right to make changes to any products and services at any time without notice. Altera assumes no responsibility or liability arising out of the application or use of any information, product, or service described herein except as expressly agreed to in writing by Altera. Altera customers are advised to obtain the latest version of device specifications before relying on any published information and before placing orders for products or services.



The simulations in this section use a Stratix® II device-based board. Because of limitations of this FPGA device family, simulations are limited to 266 MHz and 533 Mbps so that comparison to actual hardware results can be directly made.

## Stratix II High Speed Board

To properly study the dual-DIMM DDR2 SDRAM interface, the simulation and measurement setup evaluated in the following analysis features a Stratix II FPGA interfacing with two 267-MHz DDR2 SDRAM UDIMMs. This DDR2 SDRAM interface is built on the Stratix II High-Speed High-Density Board (Figure 5-2).

 For more information about the Stratix II High-Speed High-Density Board, contact your Altera® representative.

**Figure 5-2. Stratix II High-Speed Board with Dual-DIMM DDR2 SDRAM Interface**

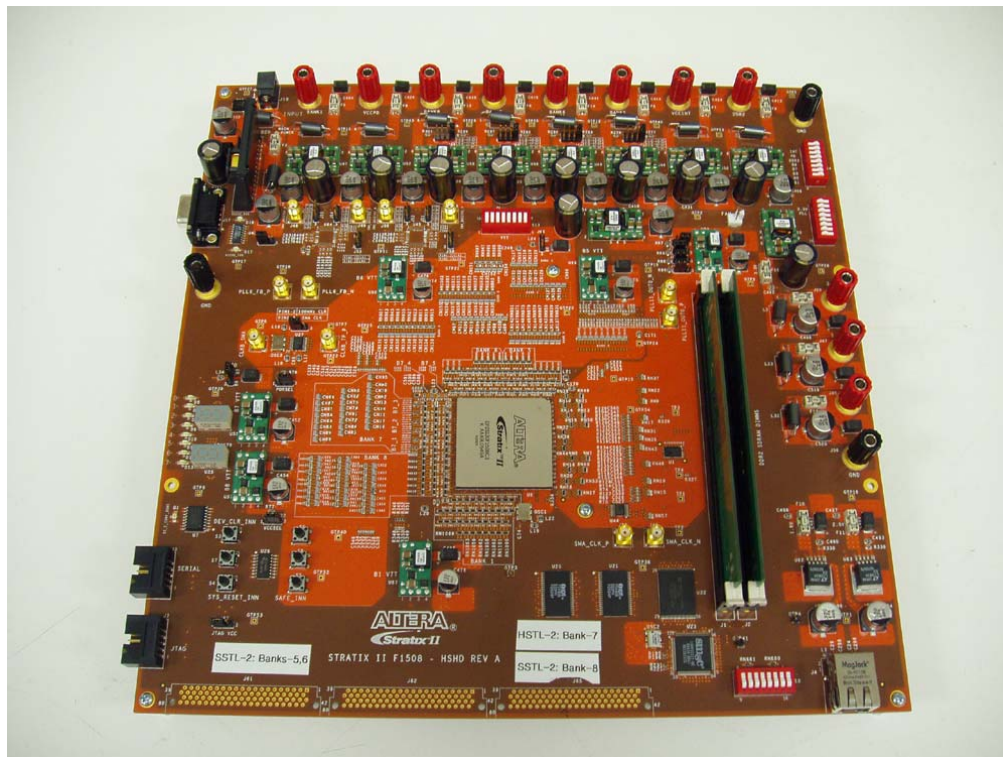

The Stratix II High-Speed Board uses a Stratix II 2S90F1508 device. For DQS, DQ, and DM signals, the board is designed without external parallel termination resistors near the DDR2 SDRAM DIMMs, to take advantage of the ODT feature of the DDR2 SDRAM components. Stratix II FPGA devices are not equipped with dynamic OCT, so external parallel termination resistors are used at the FPGA end of the line.

Stratix III and Stratix IV devices, which support dynamic OCT, do not require FPGA end parallel termination. Hence this discrete parallel termination is optional.

The DDR2 SDRAM DIMM contains a 22-Ω external series termination resistor for each data strobe and data line, so all the measurements and simulations need to account for the effect of these series termination resistors.

To correlate the bench measurements done on the Stratix II High Speed High Density Board, the simulations are performed using HyperLynx LineSim Software with IBIS models from Altera and memory vendors. Figure 5-3 is an example of the simulation setup in HyperLynx used for the simulation.

**Figure 5-3. HyperLynx Setup for Simulating the Stratix II High Speed High Density with Dual-DIMM DDR2 SDRAM Interface**

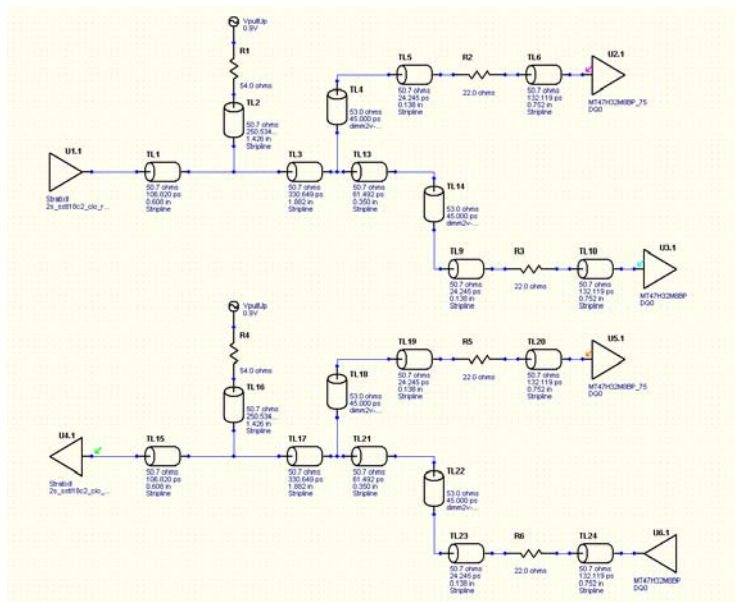

## Overview of ODT Control

When there is only a single-DIMM on the board, the ODT control is relatively straightforward. During write to the memory, the ODT feature of the memory is turned on; during read from the memory, the ODT feature of the memory is turned off. However, when there are multiple DIMMs on the board, the ODT control becomes more complicated.

With a dual-DIMM interface on the system, the controller has different options for turning the memory ODT on or off during read or write. Table 5-1 lists the DDR2 SDRAM ODT control during write to the memory; Table 5-2 during read from the memory. These DDR2 SDRAM ODT controls are recommended by Samsung Electronics. The JEDEC DDR2 specification was updated to include optional support for  $R_{TT}(\text{nominal}) = 50 \Omega$ .

 For more information about the DDR2 SDRAM ODT controls recommended by Samsung, refer to the *Samsung DDR2 Application Note: ODT (On Die Termination) Control*.

**Table 5-1. DDR2 SDRAM ODT Control—Writes <sup>(1)</sup>**

Slot 1 <sup>(2)</sup>	Slot 2 <sup>(2)</sup>	Write To	FPGA	Module in Slot 1		Module in Slot 2	
				Rank 1	Rank 2	Rank 3	Rank 4
DR	DR	Slot 1	Series 50 $\Omega$	Infinite	Infinite	75 or 50 $\Omega$	Infinite
		Slot 2	Series 50 $\Omega$	75 or 50 $\Omega$	Infinite	Infinite	infinite
SR	SR	Slot 1	Series 50 $\Omega$	Infinite	Unpopulated	75 or 50 $\Omega$	Unpopulated
		Slot 2	Series 50 $\Omega$	75 or 50 $\Omega$	Unpopulated	Infinite	Unpopulated
DR	Empty	Slot 1	Series 50 $\Omega$	150 $\Omega$	Infinite	Unpopulated	Unpopulated
Empty	DR	Slot 2	Series 50 $\Omega$	Unpopulated	Unpopulated	150 $\Omega$	Infinite
SR	Empty	Slot 1	Series 50 $\Omega$	150 $\Omega$	Unpopulated	Unpopulated	Unpopulated
Empty	SR	Slot 2	Series 50 $\Omega$	Unpopulated	Unpopulated	150 $\Omega$	Unpopulated

**Notes to Table 5-1:**

(1) For DDR2 at 400 MHz and 533 Mbps = 75  $\Omega$ ; for DDR2 at 667 MHz and 800 Mbps = 50  $\Omega$ .

(2) SR = single ranked; DR = dual ranked.

**Table 5-2. DDR2 SDRAM ODT Control—Reads <sup>(1)</sup>**

Slot 1 <sup>(2)</sup>	Slot 2 <sup>(2)</sup>	Read From	FPGA	Module in Slot 1		Module in Slot 2	
				Rank 1	Rank 2	Rank 3	Rank 4
DR	DR	Slot 1	Parallel 50 $\Omega$	Infinite	Infinite	75 or 50 $\Omega$	Infinite
		Slot 2	Parallel 50 $\Omega$	75 or 50 $\Omega$	Infinite	Infinite	Infinite
SR	SR	Slot 1	Parallel 50 $\Omega$	Infinite	Unpopulated	75 or 50 $\Omega$	Unpopulated
		Slot 2	Parallel 50 $\Omega$	75 or 50 $\Omega$	Unpopulated	Infinite	Unpopulated
DR	Empty	Slot 1	Parallel 50 $\Omega$	Infinite	Infinite	Unpopulated	Unpopulated
Empty	DR	Slot 2	Parallel 50 $\Omega$	Unpopulated	Unpopulated	Infinite	Infinite
SR	Empty	Slot 1	Parallel 50 $\Omega$	Infinite	Unpopulated	Unpopulated	Unpopulated
Empty	SR	Slot 2	Parallel 50 $\Omega$	Unpopulated	Unpopulated	Infinite	Unpopulated

**Notes to Table 5-1:**

(1) For DDR2 at 400 MHz and 533 Mbps = 75  $\Omega$ ; for DDR2 at 667 MHz and 800 Mbps = 50  $\Omega$ .

(2) SR = single ranked; DR = dual ranked.

A 54- $\Omega$  external parallel termination resistor is placed on all the data strobes and data lines near the Stratix II device on the Stratix II High Speed High Density Board. Although the characteristic impedance of the transmission is designed for 50  $\Omega$ , to account for any process variation, it is advisable to underterminate the termination seen at the receiver. This is why the termination resistors at the FPGA side use 54- $\Omega$  resistors.

## DIMM Configuration



While populating both memory slots is common in a dual-DIMM memory system, there are some instances when only one slot is populated. For example, some systems are designed to have a certain amount of memory initially and as applications get more complex, the system can be easily upgraded to accommodate more memory by populating the second memory slot without re-designing the system. The following section discusses a dual-DIMM system where the dual-DIMM system only has one slot populated at one time and a dual-DIMM system where both slots are populated. ODT controls recommended by the memory vendors listed in [Table 5-1](#) as well as other possible ODT settings will be evaluated for usefulness in an FPGA system.

## Dual-DIMM Memory Interface with Slot 1 Populated

This section focuses on a dual-DIMM memory interface where slot 1 is populated and slot 2 is unpopulated. This section examines the impact on the signal quality due to an unpopulated DIMM slot and compares it to a single-DIMM memory interface.

### FPGA Writing to Memory

In the DDR2 SDRAM, the ODT feature has two settings:  $150\ \Omega$  and  $75\ \Omega$ . In [Table 5-1](#), the recommended ODT setting for a dual DIMM configuration with one slot occupied is  $150\ \Omega$ .

-  On DDR2 SDRAM devices running at 333 MHz/667 Mbps and above, the ODT feature supports an additional setting of  $50\ \Omega$ .
-  Refer to the respective memory decathlete for additional information about the ODT settings in DDR2 SDRAM devices.

### Write to Memory Using an ODT Setting of $150\ \Omega$

[Figure 5-4](#) shows a double parallel termination scheme (Class II) using ODT on the memory with a memory-side series resistor when the FPGA is writing to the memory using a  $25\text{-}\Omega$  OCT drive strength setting on the FPGA.

**Figure 5-4. Double Parallel Termination Scheme (Class II) Using ODT on DDR2 SDRAM DIMM with Memory-Side Series Resistor**

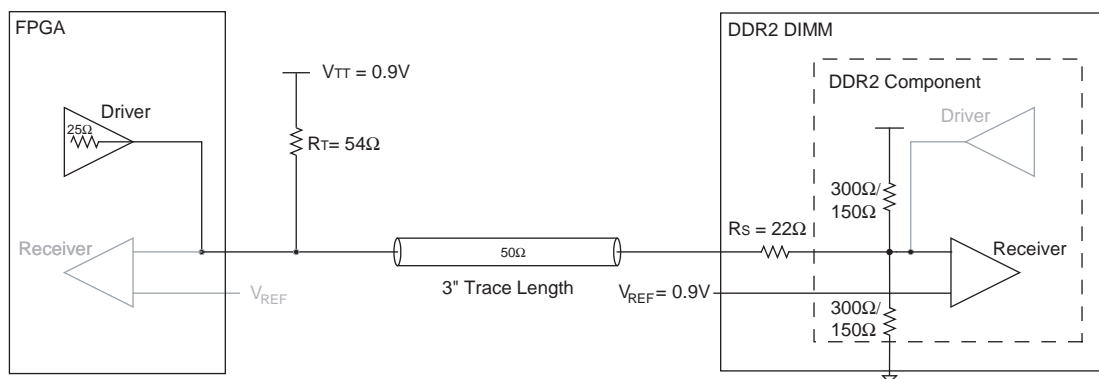

Figure 5-5 shows a HyperLynx simulation and board measurement of a signal at the memory of a double parallel termination using ODT 150  $\Omega$  with a memory-side series resistor transmission line when the FPGA is writing to the memory with a 25- $\Omega$  OCT drive strength setting.

**Figure 5-5. HyperLynx Simulation and Board Measurement of the Signal at the Memory in Slot 1 with Slot 2 Unpopulated**

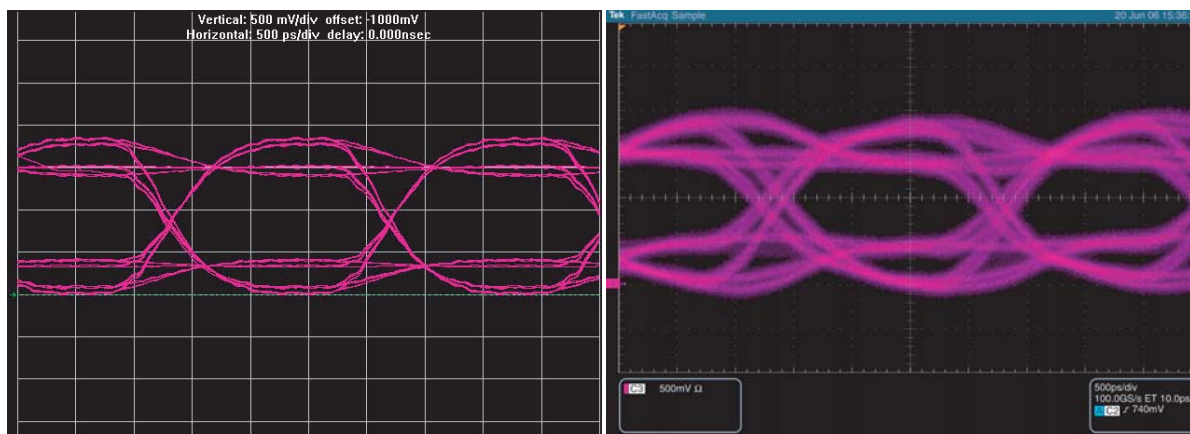

Table 5-3 summarizes the comparison between the simulation and board measurements of the signal at the memory of a single-DIMM and a dual-DIMM memory interface with slot 1 populated using a double parallel termination using an ODT setting of 150  $\Omega$  with a memory-side series resistor with a 25- $\Omega$  OCT strength setting on the FPGA.

**Table 5-3. Comparison of Signal at the Memory of a Single-DIMM and a Dual-DIMM Interface with Slot 1 Populated <sup>(1)</sup>**

Type	Eye Width (ns)	Eye Height (V)	Overshoot (V)	Undershoot (V)	Rising Edge Rate (V/ns)	Falling Edge Rate (V/ns)
<b>Dual-DIMM memory interface with slot 1 populated</b>						
Simulation	1.68	0.97	0.06	NA	2.08	1.96
Measurements	1.30	0.63	0.22	0.20	1.74	1.82
<b>Single-DIMM</b>						
Simulation	1.62	0.94	0.10	0.05	2.46	2.46
Measurements	1.34	0.77	0.04	0.13	1.56	1.39

**Note to Table 5-3:**

- (1) The simulation and board measurements of the single-DIMM DDR2 SDRAM interface are based on the Stratix II Memory Board 2. For more information about the single-DIMM DDR2 SDRAM interface, refer to the *DDR2 and DDR3 SDRAM Board Design Guidelines* chapter.

Table 5-3 indicates that there is not much difference between a single-DIMM memory interface or a dual-DIMM memory interface with slot 1 populated. The over and undershooting observed in both the simulations and board measurements can be attributed to the use of the ODT setting of 150  $\Omega$  on the memory resulting in over-termination at the receiver. In addition, there is no significant effect of the extra DIMM connector due to the unpopulated slot.

When the ODT setting is set to  $75\ \Omega$ , there is no difference in the eye width and height compared to the ODT setting of  $150\ \Omega$ . However, there is no overshoot and undershoot when the ODT setting is set to  $75\ \Omega$ , which is attributed to proper termination resulting in matched impedance seen by the DDR2 SDRAM devices.

 For information about results obtained from using an ODT setting of  $75\ \Omega$  refer to page 5-24.

### Reading from Memory

During read from the memory, the ODT feature is turned off. Thus, there is no difference between using an ODT setting of  $150\ \Omega$  and  $75\ \Omega$ . As such, the termination scheme becomes a single parallel termination scheme (Class I) where there is an external resistor on the FPGA side and a series resistor on the memory side as shown in Figure 5-6.

**Figure 5-6. Single Parallel Termination Scheme (Class I) Using External Resistor and Memory-Side Series Resistor**

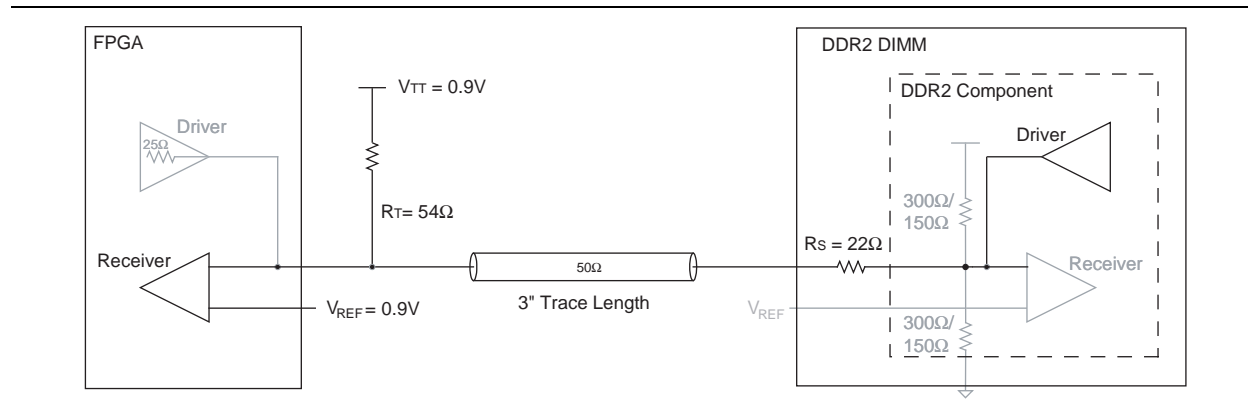

Figure 5-7 shows the simulation and board measurement of the signal at the FPGA of a single parallel termination using an external parallel resistor on the FPGA side with a memory-side series resistor with full drive strength setting on the memory.

**Figure 5-7. HyperLynx Simulation and Board Measurement of the Signal at the FPGA When Reading From Slot 1 With Slot 2 Unpopulated**

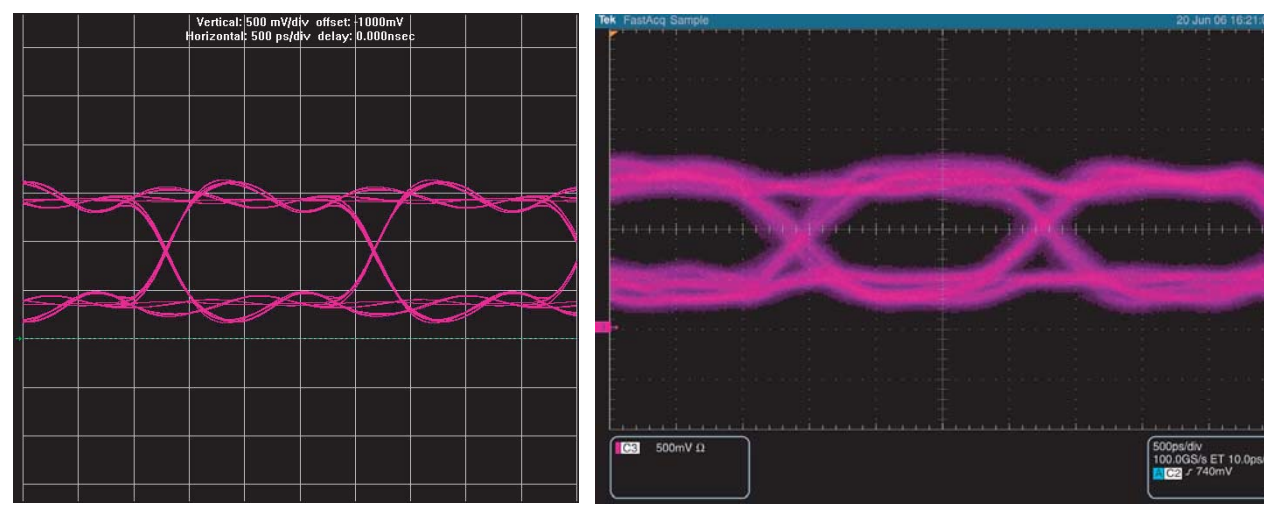

Table 5-4 summarizes the comparison between the simulation and board measurements of the signal seen at the FPGA of a single-DIMM and a dual-DIMM memory interface with a slot 1 populated memory interface using a single parallel termination using an external parallel resistor at the FPGA with a memory-side series resistor with full strength setting on the memory.

**Table 5-4. Comparison of Signal at the FPGA of a Dual-DIMM Memory Interface with Slot 1 Populated <sup>(1)</sup>**

Type	Eye Width (ns)	Eye Height (V)	Overshoot (V)	Undershoot (V)	Rising Edge Rate (V/ns)	Falling Edge Rate (V/ns)
<b>Dual-DIMM memory interface with slot 1 populated</b>						
Simulation	1.76	0.80	NA	NA	2.29	2.29
Measurements	1.08	0.59	NA	NA	1.14	1.59
<b>Single-DIMM<sup>1</sup></b>						
Simulation	1.80	0.95	NA	NA	2.67	2.46
Measurements	1.03	0.58	NA	NA	1.10	1.30

**Note to Table 5-4:**

- (1) The simulation and board measurements of the single-DIMM DDR2 SDRAM interface are based on the Stratix II Memory Board 2. For more information about the single-DIMM DDR2 SDRAM interface, refer to the *DDR2 and DDR3 SDRAM Board Design Guidelines* chapter.

Table 5-4 demonstrates that there is not much difference between a single-DIMM memory interface or a dual-DIMM memory interface with only slot 1 populated. There is no significant effect of the extra DIMM connector due to the unpopulated slot.

## Dual-DIMM with Slot 2 Populated

This section focuses on a dual-DIMM memory interface where slot 2 is populated and slot 1 is unpopulated. Specifically, this section discusses the impact of location of the DIMM on the signal quality.

### FPGA Writing to Memory

The previous section focused on the dual-DIMM memory interface where slot 1 is populated resulting in the memory being located closer to the FPGA. When slot 2 is populated, the memory is located further away from the FPGA, resulting in additional trace length that potentially affects the signal quality seen by the memory. The next section explores if there are any differences between populating slot 1 and slot 2 of the dual-DIMM memory interface.

### Write to Memory Using an ODT Setting of 150Ω

Figure 5-8 shows the double parallel termination scheme (Class II) using ODT on the memory with the memory-side series resistor when the FPGA is writing to the memory using a 25-Ω OCT drive strength setting on the FPGA.

**Figure 5-8. Double Parallel Termination Scheme (Class II) Using ODT on DDR2 SDRAM DIMM with Memory-side Series Resistor**

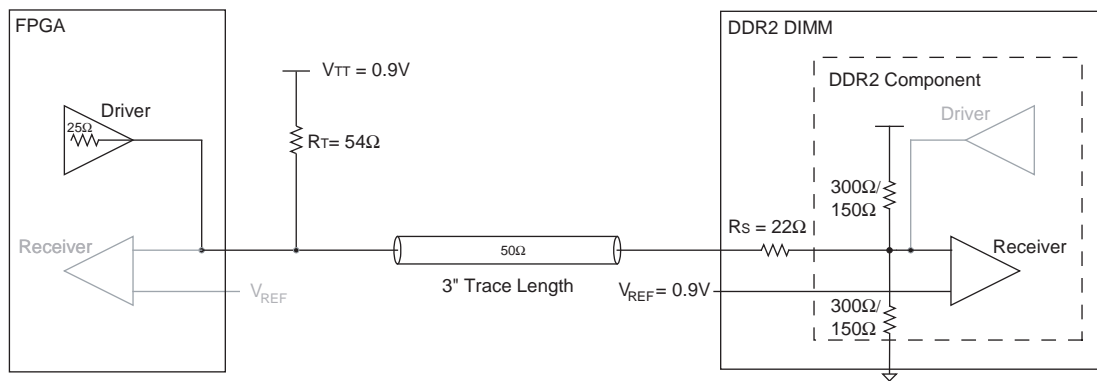

Figure 5-9 shows the simulation and board measurement of the signal at the memory of a double parallel termination using an ODT setting of 150 Ω with a memory-side series resistor transmission line when the FPGA is writing to the memory with a 25-Ω OCT drive strength setting.

**Figure 5-9. HyperLynx Simulation and Board Measurement of the Signal at the Memory in Slot 2 With Slot 1 Unpopulated**

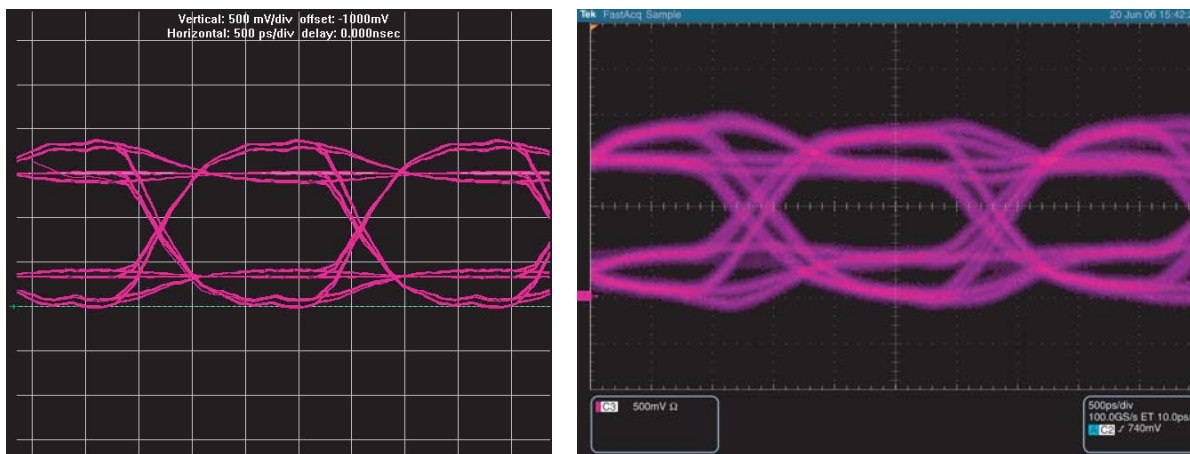

Table 5-5 summarizes the comparison between the simulation and board measurements of the signal seen at the DDR2 SDRAM DIMM of a dual-DIMM memory interface with either only slot 1 populated or only slot 2 populated using a double parallel termination using an ODT setting of  $150\ \Omega$  with a memory-side series resistor with a  $25\text{-}\Omega$  OCT strength setting on the FPGA.

**Table 5-5. Comparison of Signal at the Memory of a Dual-DIMM Interface with Either Only Slot 1 Populated or Only Slot 2 Populated**

Type	Eye Width (ns)	Eye Height (V)	Overshoot (V)	Undershoot (V)	Rising Edge Rate (V/ns)	Falling Edge Rate (V/ns)
<b>Dual-DIMM Memory Interface with Slot 2 Populated</b>						
Simulation	1.69	0.94	0.07	0.02	1.96	2.08
Measurements	1.28	0.68	0.24	0.20	1.60	1.60
<b>Dual-DIMM Memory Interface with Slot 1 Populated</b>						
Simulation	1.68	0.97	0.06	NA	2.08	2.08
Measurements	1.30	0.63	0.22	0.20	1.74	1.82

Table 5-5 shows that there is not much difference between populating slot 1 or slot 2 in a dual-DIMM memory interface. The over and undershooting observed in both the simulations and board measurements can be attributed to the use of the ODT setting of  $150\ \Omega$  on the memory, resulting in under-termination at the receiver.

When the ODT setting is set to  $75\ \Omega$ , there is no difference in the eye width and height compared to the ODT setting of  $150\ \Omega$ . However, there is no overshoot and undershoot when the ODT setting is set to  $75\ \Omega$ , which is attributed to proper termination resulting in matched impedance seen by the DDR2 SDRAM devices.

 For detailed results for the ODT setting of  $75\ \Omega$ , refer to [page 5-25](#).

### Reading from Memory

During read from memory, the ODT feature is turned off, thus there is no difference between using an ODT setting of  $150\ \Omega$  and  $75\ \Omega$ . As such, the termination scheme becomes a single parallel termination scheme (Class I) where there is an external resistor on the FPGA side and a series resistor on the memory side, as shown in [Figure 5-10](#).

**Figure 5-10. Single Parallel Termination Scheme (Class I) Using External Resistor and Memory-Side Series Resistor**

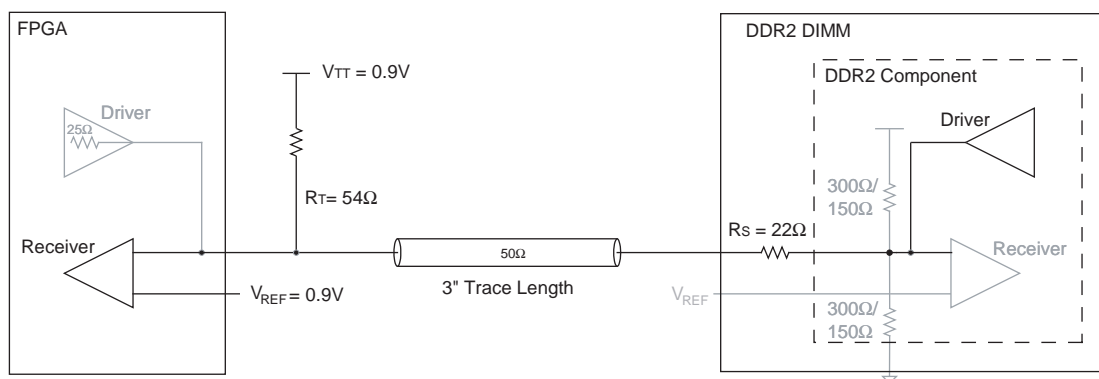

Figure 5-11 shows the simulation and board measurement of the signal at the FPGA of a single parallel termination using an external parallel resistor on the FPGA side with a memory-side series resistor with full drive strength setting on the memory.

**Figure 5-11. HyperLynx Simulation and Board Measurement of the Signal at the FPGA When Reading From Slot 2 With Slot 1 Unpopulated**

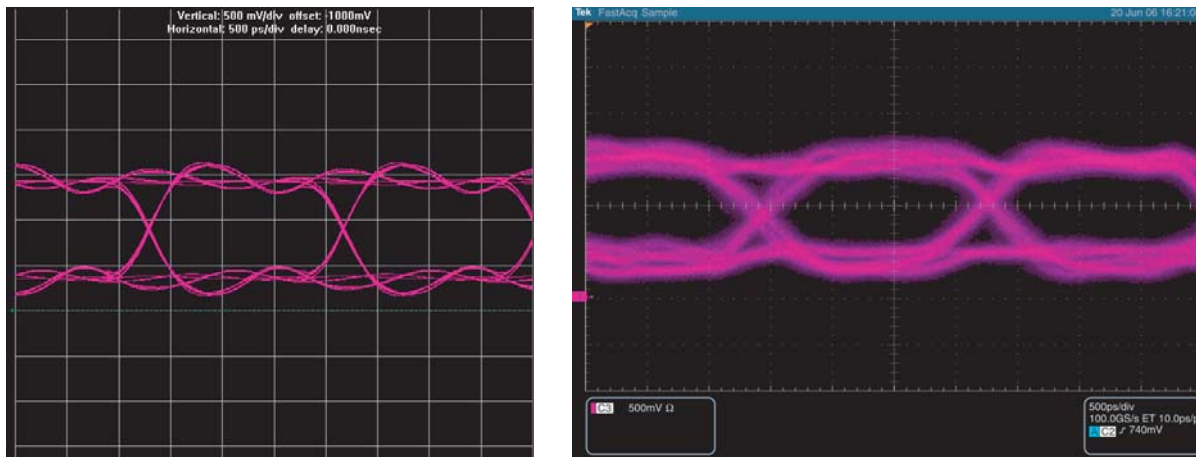

Table 5-6 summarizes the comparison between the simulation and board measurements of the signal seen at the FPGA of a dual-DIMM memory interface with either slot 1 or slot 2 populated using a single parallel termination using an external parallel resistor at the FPGA with a memory-side series resistor with full strength setting on the memory.

**Table 5-6. Comparison of the Signal at the FPGA of a Dual-DIMM Memory Interface with Either Slot 1 or Slot 2 Populated**

Type	Eye Width (ns)	Eye Height (V)	Overshoot (V)	Undershoot (V)	Rising Edge Rate (V/ns)	Falling Edge Rate (V/ns)
<b>Slot 2 Populated</b>						
Simulation	1.80	0.80	NA	NA	3.09	2.57
Measurements	1.17	0.66	NA	NA	1.25	1.54
<b>Slot 1 Populated</b>						
Simulation	1.80	0.95	NA	NA	2.67	2.46
Measurements	1.08	0.59	NA	NA	1.14	1.59

From Table 5-6, you can see the signal seen at the FPGA is similar whether the memory DIMM is located at either slot 1 or slot 2.

## Dual-DIMM Memory Interface with Both Slot 1 and Slot 2 Populated

This section focuses on a dual-DIMM memory interface where both slot 1 and slot 2 are populated. As such, you can write to either the memory in slot 1 or the memory in slot 2.

### FPGA Writing to Memory

In Table 5-1, the recommended ODT setting for a dual DIMM configuration with both slots occupied is  $75\ \Omega$ . Since there is an option for an ODT setting of  $150\ \Omega$ , this section explores the usage of the  $150\ \Omega$  setting and compares the results to that of the recommended  $75\ \Omega$ .

### Write to Memory in Slot 1 Using an ODT Setting of $75\ \Omega$

Figure 5-12 shows the double parallel termination scheme (Class II) using ODT on the memory with the memory-side series resistor when the FPGA is writing to the memory using a  $25\ \Omega$  OCT drive strength setting on the FPGA. In this scenario, the FPGA is writing to the memory in slot 1 and the ODT feature of the memory at slot 2 is turned on.

**Figure 5-12. Double Parallel Termination Scheme (Class II) Using ODT on DDR2 SDRAM DIMM with a Memory-Side Series Resistor**

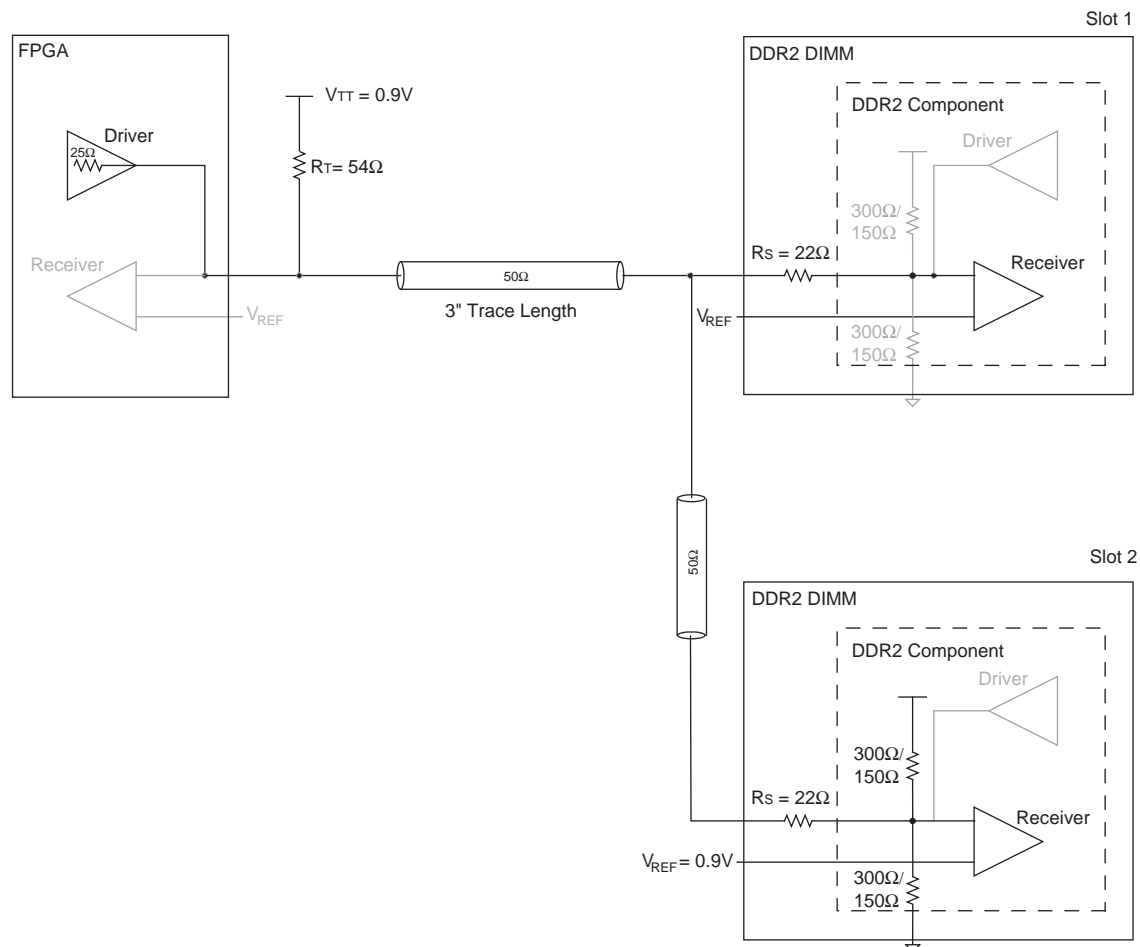

Figure 5-13 shows a HyperLynx simulation and board measurement of the signal at the memory in slot 1 of a double parallel termination using an ODT setting of 75  $\Omega$  with a memory-side series resistor transmission line when the FPGA is writing to the memory with a 25- $\Omega$  OCT drive strength setting.

**Figure 5-13. HyperLynx Simulation and Board Measurements of the Signal at the Memory in Slot 1 with Both Slots Populated**

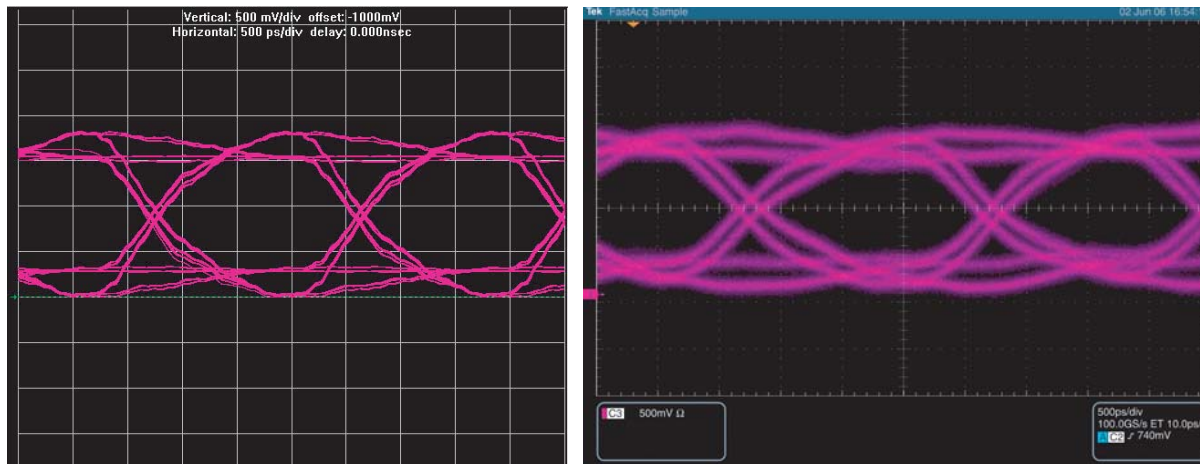



Table 5-7 summarizes the comparison of the signal at the memory of a dual-DIMM memory interface with one slot and with both slots populated using a double parallel termination using an ODT setting of 75  $\Omega$  with a memory-side series resistor with a 25- $\Omega$  OCT strength setting on the FPGA.

**Table 5-7. Comparison of the Signal at the Memory of a Dual-DIMM Interface With One Slot and With Both Slots Populated**

Type	Eye Width (ns)	Eye Height (V)	Overshoot (V)	Undershoot (V)	Rising Edge Rate (V/ns)	Falling Edge Rate (V/ns)
<b>Dual-DIMM Interface with Both Slots Populated Writing to Slot 1</b>						
Simulation	1.60	1.18	0.02	NA	1.71	1.71
Measurements	0.97	0.77	0.05	0.04	1.25	1.25
<b>Dual-DIMM Interface with Slot 1 Populated</b>						
Simulation	1.68	0.97	0.06	NA	2.08	2.08
Measurements	1.30	0.63	0.22	0.20	1.74	1.82

Table 5-7 shows that there is not much difference in the eye height between populating one slot or both slots. However, the additional loading due to the additional memory DIMM results in a slower edge rate, which results in smaller eye width and degrades the setup and hold time of the memory. This reduces the available data valid window.

When the ODT setting is set to 150  $\Omega$ , there is no difference in the eye width and height compared to the ODT setting of 75  $\Omega$ . However, there is some overshoot and undershoot when the ODT setting is set to 150  $\Omega$ , which is attributed to under termination resulting in mismatched impedance seen by the DDR2 SDRAM devices.

 For more information about the results obtained from using an ODT setting of 150  $\Omega$ , refer to [page 5-26](#).

### Write to Memory in Slot 2 Using an ODT Setting of 75- $\Omega$

In this scenario, the FPGA is writing to the memory in slot 2 and the ODT feature of the memory at slot 1 is turned on. [Figure 5-14](#) shows the HyperLynx simulation and board measurement of the signal at the memory in slot 1 of a double parallel termination using an ODT setting of 75  $\Omega$  with a memory-side series resistor transmission line when the FPGA is writing to the memory with a 25- $\Omega$  OCT drive strength setting.

**Figure 5-14. HyperLynx Simulation and Board Measurements of the Signal at the Memory in Slot 2 With Both Slots Populated**

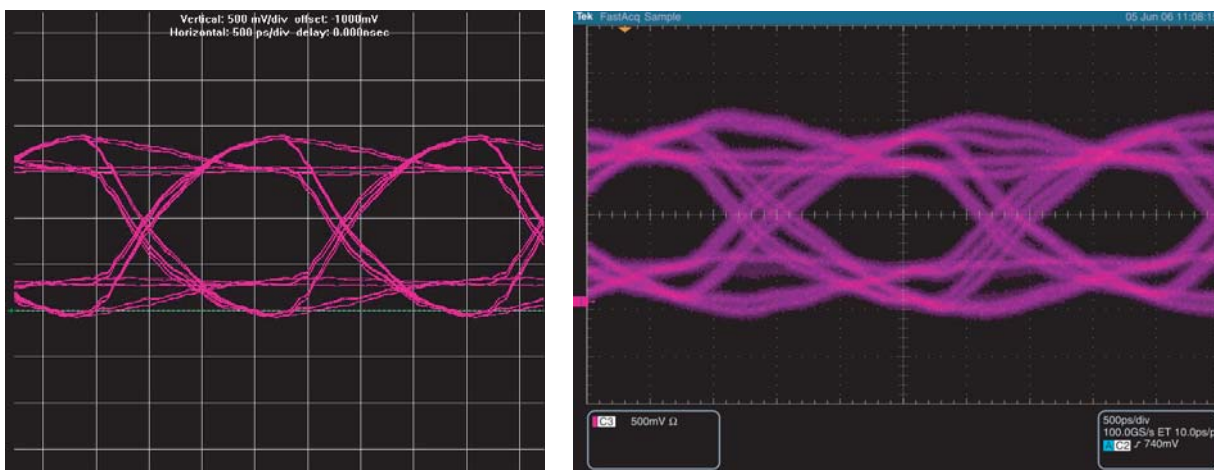

[Table 5-8](#) summarizes the comparison of the signal at the memory of a dual-DIMM memory interface with slot 1 populated using a double parallel termination using an ODT setting of 75  $\Omega$  with a memory-side series resistor with a 25- $\Omega$  OCT strength setting on the FPGA.

**Table 5-8. Comparison of the Signal at the Memory of a Dual-DIMM Interface With Both Slots Populated**

Type	Eye Width (ns)	Eye Height (V)	Overshoot (V)	Undershoot (V)	Rise Edge Rate (V/ns)	Falling Edge Rate (V/ns)
<b>Dual-DIMM Interface with Both Slots Populated Writing to Slot 2</b>						
Simulation	1.60	1.16	0.10	0.08	1.68	1.60
Measurements	1.10	0.85	0.16	0.19	1.11	1.25
<b>Dual-DIMM Interface with Both Slots Populated Writing to Slot 1</b>						
Simulation	1.60	1.18	0.02	NA	1.71	1.71
Measurements	1.30	0.77	0.05	0.04	1.25	1.25

From [Table 5-8](#), you can see that both simulations and board measurements demonstrate that the eye width is larger when writing to slot 1, which is due to better edge rate seen when writing to slot 1. The improvement on the eye when writing to slot 1 can be attributed to the location of the termination. When you are writing to slot 1, the ODT feature of slot 2 is turned on, resulting in a fly-by topology. When you are writing to slot 2, the ODT feature of slot 1 is turned on resulting in a non fly-by topology.

When the ODT setting is set to 150  $\Omega$ , there is no difference in the eye width and height compared to the ODT setting of 75  $\Omega$ . However, there is some overshoot and undershoot when the ODT setting is set to 150  $\Omega$ , which is attributed to under termination resulting in mismatched impedance seen by the DDR2 SDRAM devices.

For more information about the results obtained from using an ODT setting of 150  $\Omega$ , refer to [“Write to Memory in Slot 2 Using an ODT Setting of 150  \$\Omega\$  With Both Slots Populated”](#) on page 5-27.

### Reading From Memory

In [Table 5-2](#), the recommended ODT setting for a dual-DIMM configuration with both slots occupied is to turn on the ODT feature using a setting of 75  $\Omega$  on the slot that is not read from. As there is an option for an ODT setting of 150  $\Omega$ , this section explores the usage of the 150  $\Omega$  setting and compares the results to that of the recommended 75  $\Omega$ .

**Read From Memory in Slot 1 Using an ODT Setting of  $75\text{-}\Omega$  on Slot 2**

Figure 5-15 shows the double parallel termination scheme (Class II) using ODT on the memory with the memory-side series resistor when the FPGA is reading from the memory using a full drive strength setting on the memory. In this scenario, the FPGA is reading from the memory in slot 1 and the ODT feature of the memory at slot 2 is turned on.

**Figure 5-15. Double Parallel Termination Scheme (Class II) Using External Resistor and Memory-Side Series Resistor and ODT Feature Turned On**

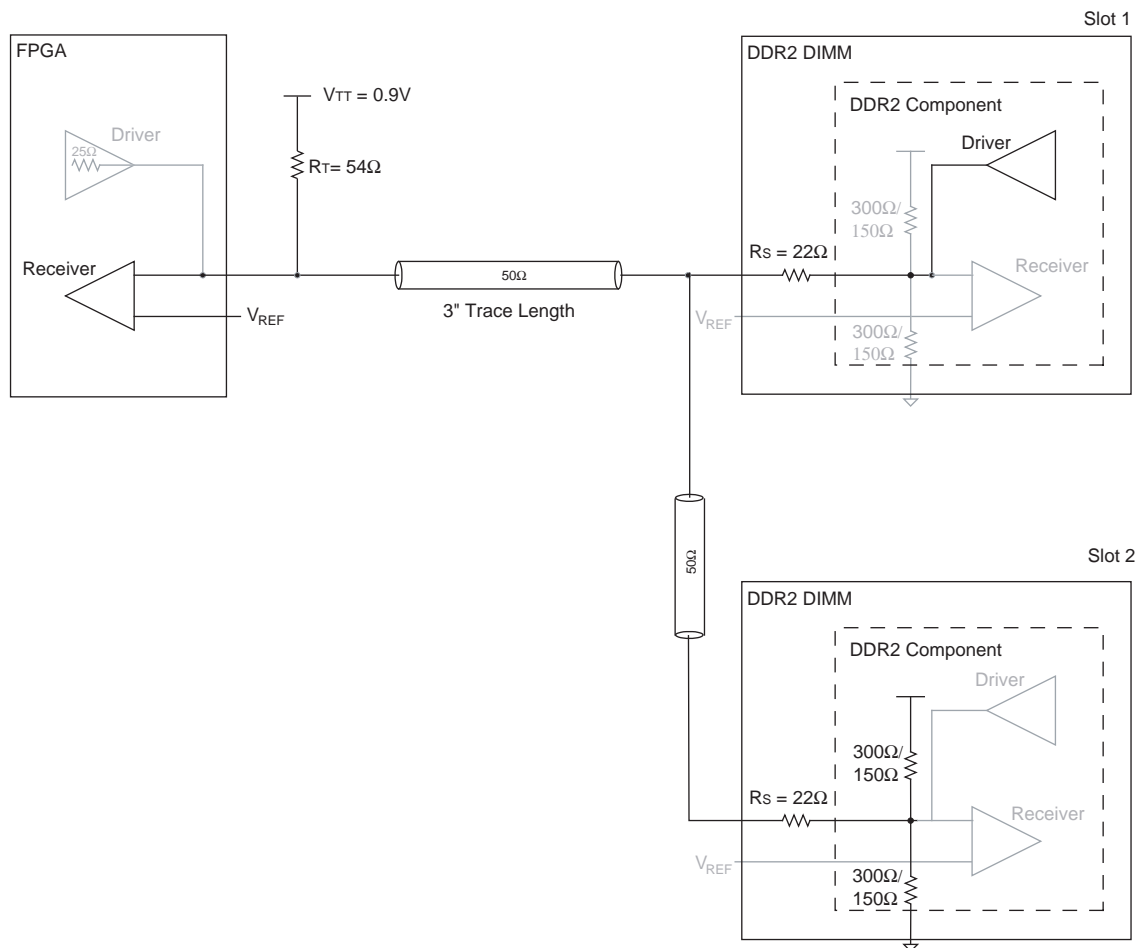
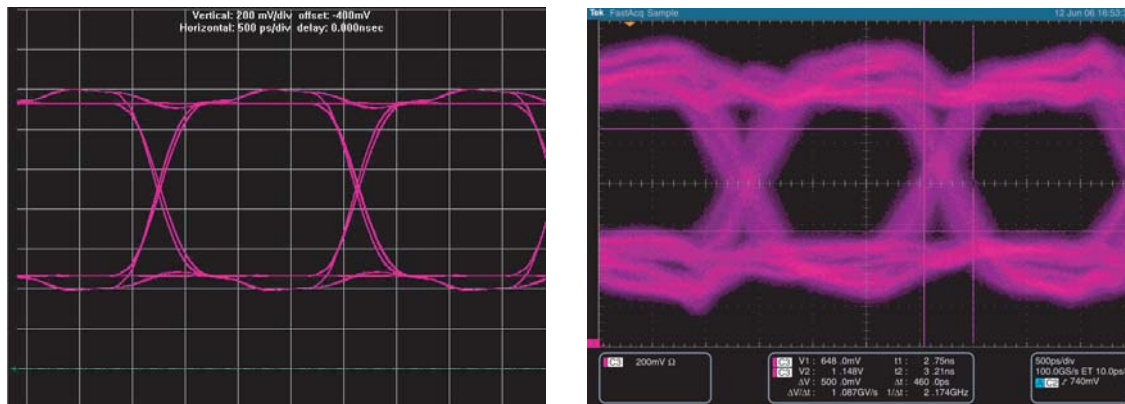

Figure 5-16 shows the simulation and board measurement of the signal at the FPGA when the FPGA is reading from the memory in slot 1 using a full drive strength setting on the memory.

**Figure 5-16. HyperLynx Simulation and Board Measurement of the Signal at the FPGA When Reading From Slot 1 With Both Slots Populated <sup>(1)</sup>**



**Note to Figure 5-16:**

(1) The vertical scale used for the simulation and measurement is set to 200 mV per division.

Table 5-9 summarizes the comparison between the simulation and board measurements of the signal seen at the FPGA of a dual-DIMM memory interface with both slots populated and a dual-DIMM memory interface with a slot 1 populated memory interface.

**Table 5-9. Comparison of the Signal at the FPGA of a Dual-DIMM Interface Reading From Slot 1 With One Slot and With Both Slots Populated**

Type	Eye Width (ns)	Eye Height (V)	Overshoot (V)	Undershoot (V)	Rising Edge Rate (V/ns)	Falling Edge Rate (V/ns)
<b>Dual-DIMM with One Slot Populated with an ODT Setting of 75-Ω on Slot 2</b>						
Simulation	1.74	0.87	NA	NA	1.91	1.88
Measurements	0.86	0.58	NA	NA	1.11	1.09
<b>Dual-DIMM with One Slot Populated in Slot 1 without ODT Setting</b>						
Simulation	1.76	0.80	NA	NA	2.29	2.29
Measurements	1.08	0.59	NA	NA	1.14	1.59

Table 5-9 shows that when both slots are populated, the additional loading due to the additional memory DIMM results in a slower edge rate, which results in a degradation in the eye width.

For more information about the results obtained from using an ODT setting of 150 Ω, refer to “Read from Memory in Slot 1 Using an ODT Setting of 150 Ω on Slot 2 with Both Slots Populated” on page 5-28.

**Read From Memory in Slot 2 Using an ODT Setting of  $75\text{-}\Omega$  on Slot 1**

In this scenario, the FPGA is reading from the memory in slot 2 and the ODT feature of the memory at slot 1 is turned on.

**Figure 5-17. Double Parallel Termination Scheme (Class II) Using External Resistor and a Memory-Side Series Resistor and ODT Feature Turned On**

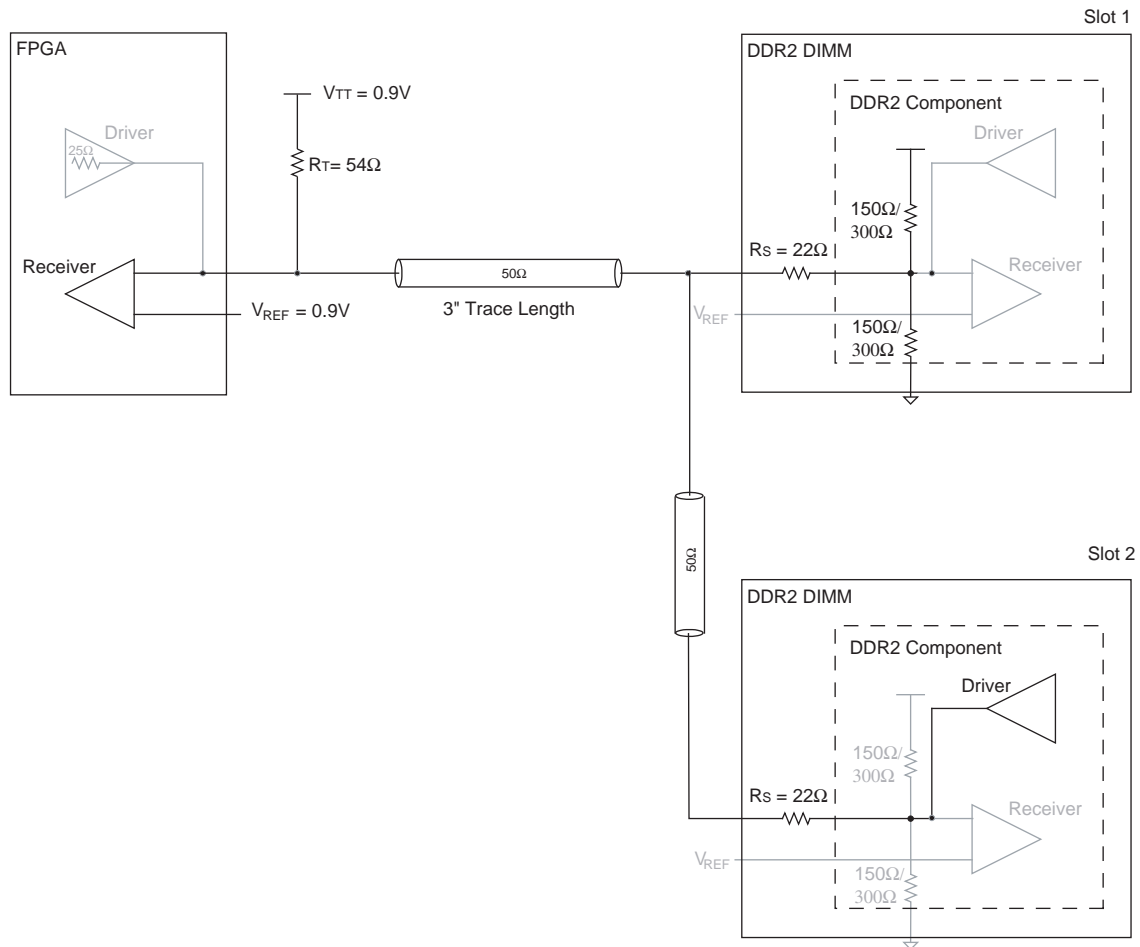
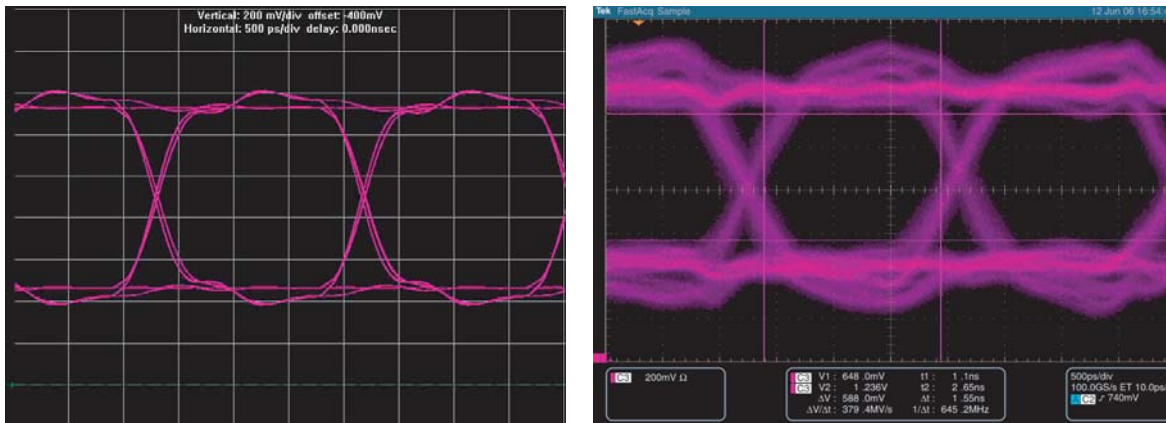

Figure 5-18 shows the HyperLynx simulation and board measurement of the signal at the FPGA of a double parallel termination using an external parallel resistor on the FPGA side with a memory-side series resistor and an ODT setting of 75  $\Omega$  with a full drive strength setting on the memory.

**Figure 5-18. HyperLynx Simulation and Board Measurements of the Signal at the FPGA When Reading From Slot 2 With Both Slots Populated (1)**



**Note to Figure 5-18:**

(1) The vertical scale used for the simulation and measurement is set to 200 mV per division.

Table 5-10 summarizes the comparison between the simulation and board measurements of the signal seen at the FPGA of a dual-DIMM memory interface with both slots populated and a dual-DIMM memory interface with a slot 1 populated memory interface.

**Table 5-10. Comparison of the Signal at the FPGA of a Dual-DIMM Interface Reading From Slot 2 With One Slot and With Both Slots Populated**

Type	Eye Width (ns)	Eye Height (V)	Overshoot (V)	Undershoot (V)	Rising Edge Rate (V/ns)	Falling Edge Rate (V/ns)
<b>Dual-DIMM with Both Slots Populated with an ODT Setting of 75-<math>\Omega</math> Setting on Slot 1</b>						
Simulation	1.70	0.81	NA	NA	1.72	1.99
Measurements	0.87	0.59	NA	NA	1.09	1.14
<b>Dual-DIMM with One Slot Populated in Slot 2 without an ODT Setting</b>						
Simulation	1.80	0.80	NA	NA	3.09	2.57
Measurements	1.17	0.66	NA	NA	1.25	1.54

Table 5-10 shows that when only one slot is populated in a dual-DIMM memory interface, the eye width is larger as compared to a dual-DIMM memory interface with both slots populated. This can be attributed to the loading from the DIMM located in slot 1.

When the ODT setting is set to 150  $\Omega$ , there is no difference in the signal quality compared to the ODT setting of 75  $\Omega$ .

For more information about the results obtained from using an ODT setting of  $150\ \Omega$ , refer to “Read From Memory in Slot 2 Using an ODT Setting of  $150\ \Omega$  on Slot 1 With Both Slots Populated” on page 5-29.

## Dual-DIMM DDR2 Clock, Address, and Command Termination and Topology

The address and command signals on a DDR2 SDRAM interface are unidirectional signals that the FPGA memory controller drives to the DIMM slots. These signals are always Class-I terminated at the memory end of the line (Figure 5-19). Always place DDR2 SDRAM address and command Class-I termination after the last DIMM. The interface can have one or two DIMMs, but never more than two DIMMs total.

**Figure 5-19. Multi DIMM DDR2 Address and Command Termination Topology**

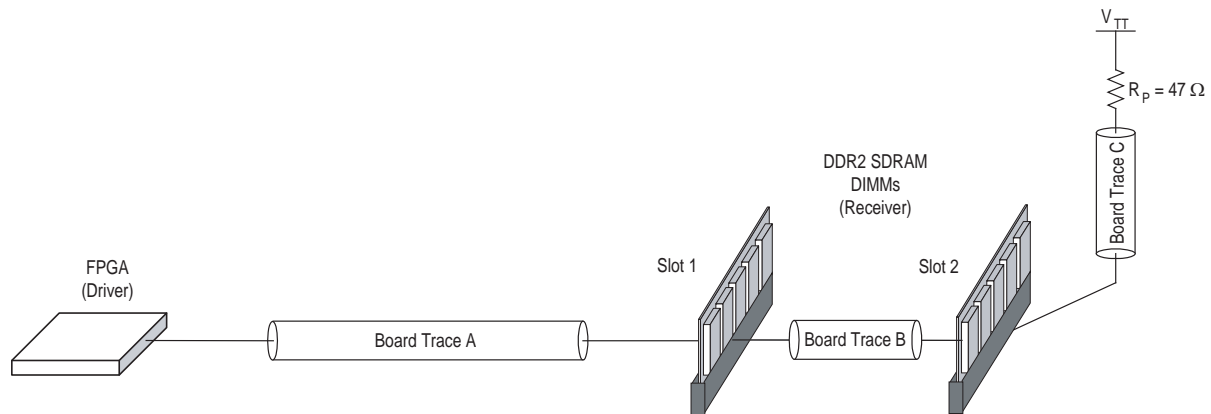

In Figure 5-19, observe the following points:

- Board trace A = 1.9 to 4.5 inches (48 to 115 mm)
- Board trace B = 0.425 inches (10.795 mm)
- Board trace C = 0.2 to 0.55 inches (5 to 13 mm)
- Total of board trace A + B + C = 2.5 to 5 inches (63 to 127 mm)
- $R_p = 36$  to  $56\ \Omega$
- Length match all address and command signals to +250 mils (+5 mm) or  $\pm 50$  ps of memory clock length at the DIMM.

You may place a compensation capacitor directly before the first DIMM slot 1 to improve signal quality on the address and command signal group. If you fit a capacitor, Altera recommends a value of 24 pF.



For more information, refer to *Micron TN47-01*.

## Address and Command Signals

The address and command group of signals: bank address, address, RAS#, CAS#, and WE#, operate a different toggle rate depending on whether you implement a full-rate or half-rate memory controller.

In full-rate designs, the address and command group of signals are 1T signals, which means that the signals can change every memory clock cycle. Address and command signals are also single data rate (SDR). Hence in a full-rate PHY design, the address and command signals operate at a maximum frequency of  $0.5 \times$  the data rate. For example in a 266-MHz full rate design, the maximum address and command frequency is 133 MHz.

In half-rate designs the address and command group of signals are 2T signals, which means that the signals change only every two memory clock cycles. As the signals are also SDR, in a half-rate PHY design, the address and command signals operate at a maximum frequency of  $0.25 \times$  the data rate. For example, in a 400-MHz half-rate design, the maximum address and command frequency is 100 MHz.

## Control Group Signals

The control group of signals: chip select CS#, clock enable CKE, and ODT are always 1T regardless of whether you implement a full-rate or half-rate design. As the signals are also SDR, the control group signals operate at a maximum frequency of  $0.5 \times$  the data rate. For example, in a 400-MHz design, the maximum control group frequency is 200 MHz.

## Clock Group Signals

Depending on the specific form factor, DDR2 SDRAM DIMMs have two or three differential clock pairs, to ensure that the loading on the clock signals is not excessive. The clock signals are always terminated on the DIMMs and hence no termination is required on your PCB. Additionally, each DIMM slot is required to have its own dedicated set of clock signals. Hence clock signals are always point-to-point from the FPGA PHY to each individual DIMM slot. Individual memory clock signals should never be shared between two DIMM slots.

A typical two slot DDR2 DIMM design therefore has six differential memory clock pairs—three to the first DIMM and three to the second DIMM. All six memory clock pairs must be delay matched to each other to  $\pm 25$  mils ( $\pm 0.635$  mm) and  $\pm 10$  mils ( $\pm 0.254$  mm) for each CLK to CLK# signal.

You may place a compensation capacitor between each clock pair directly before the DIMM connector, to improve the clock slew rates. As FPGA devices have fully programmable drive strength and slew rate options, this capacitor is usually not required for FPGA design. However, Altera advise that you simulate your specific implementation to ascertain if this capacitor is required or not. If fitted the best value is typically 5 pF.

## DDR3 SDRAM

This section details the system implementation of a dual slot unbuffered DDR3 SDRAM interface, operating at up to 400 MHz and 800 Mbps data rates. Figure 5–20 shows a typical DQS, DQ, and DM, and address and command signal topology for a dual-DIMM interface configuration, using the ODT feature of the DDR3 SDRAM components combined with the dynamic OCT features available in Stratix III and Stratix IV devices.

**Figure 5–20. Multi DIMM DDR3 DQS, DQ, and DM, and Address and Command Termination Topology**

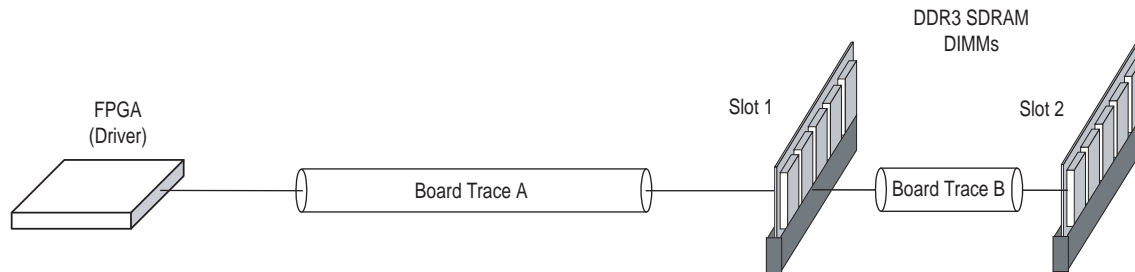

In Figure 5–20, observe the following points:

- Board trace A = 1.9 to 4.5 inches (48 to 115 mm)
- Board trace B = 0.425 inches (10.795 mm)
- This topology to both DIMMs is accurate for DQS, DQ, and DM, and address and command signals
- This topology is not correct for CLK and CLK# and control group signals (CS#, CKE, and ODT), which are always point-to-point single rank only.

### Comparison of DDR3 and DDR2 DQ and DQS ODT Features and Topology

DDR3 and DDR2 SDRAM systems are quite similar. The physical topology of the data group of signals may be considered nearly identical. The FPGA end (driver) I/O standard changes from SSTL18 for DDR2 to SSTL15 for DDR3, but all other OCT settings are identical. DDR3 offers enhanced ODT options for termination and drive-strength settings at the memory end of the line.

- 
 For more information, refer to the DDR3 SDRAM ODT matrix for writes and the DDR3 SDRAM ODT matrix for reads tables in the *DDR2 and DDR3 SDRAM Board Design Guidelines* chapter.

## Dual-DIMM DDR3 Clock, Address, and Command Termination and Topology

One significant difference between DDR3 and DDR2 DIMM based interfaces is the address, command and clock signals. DDR3 uses a daisy chained based architecture when using JEDEC standard modules. The address, command, and clock signals are routed on each module in a daisy chain and feature a fly-by termination on the module. Impedance matching is required to make the dual-DIMM topology work effectively—40 to 50  $\Omega$  traces should be targeted on the main board.

### Address and Command Signals

Two UDIMMs result in twice the effective load on the address and command signals, which reduces the slew rate and makes it more difficult to meet setup and hold timing ( $t_{IS}$  and  $t_{IH}$ ). However, address and command signals operate at half the interface rate and are SDR. Hence a 400-Mbps data rate equates to an address and command fundamental frequency of 100 MHz.

### Control Group Signals

The control group signals (chip Select CS#, clock enable CKE, and ODT) are only ever single rank. A dual-rank capable DDR3 DIMM slot has two copies of each signal, and a dual-DIMM slot interface has four copies of each signal. Hence the signal quality of these signals is identical to a single rank case. The control group of signals, are always 1T regardless of whether you implement a full-rate or half-rate design. As the signals are also SDR, the control group signals operate at a maximum frequency of  $0.5 \times$  the data rate. For example, in a 400 MHz design, the maximum control group frequency is 200 MHz.

### Clock Group Signals

Like the control group signals, the clock signals in DDR3 SDRAM are only ever single rank loaded. A dual-rank capable DDR3 DIMM slot has two copies of the signal, and a dual-slot interface has four copies of the `mem_clk` and `mem_clk_n` signals.



For more information about a DDR3 two-DIMM system design, refer to Micron *TN-41-08: DDR3 Design Guide for Two-DIMM Systems*.



The Altera DDR3 ALTMEMPHY megafunction does not support the 1T address and command topology referred to in this Micron Technical Note—only 2T implementations are supported.

## Write to Memory in Slot 1 Using an ODT Setting of 75 $\Omega$ With One Slot Populated

Figure 5-21 shows the simulation and board measurement of the signal at the memory when the FPGA is writing to the memory with an ODT setting of 75  $\Omega$  and using a 25- $\Omega$  OCT drive strength setting on the FPGA.

**Figure 5-21. HyperLynx Simulation and Board Measurement of the Signal at the Memory in Slot 1 With Slot 2 Unpopulated**

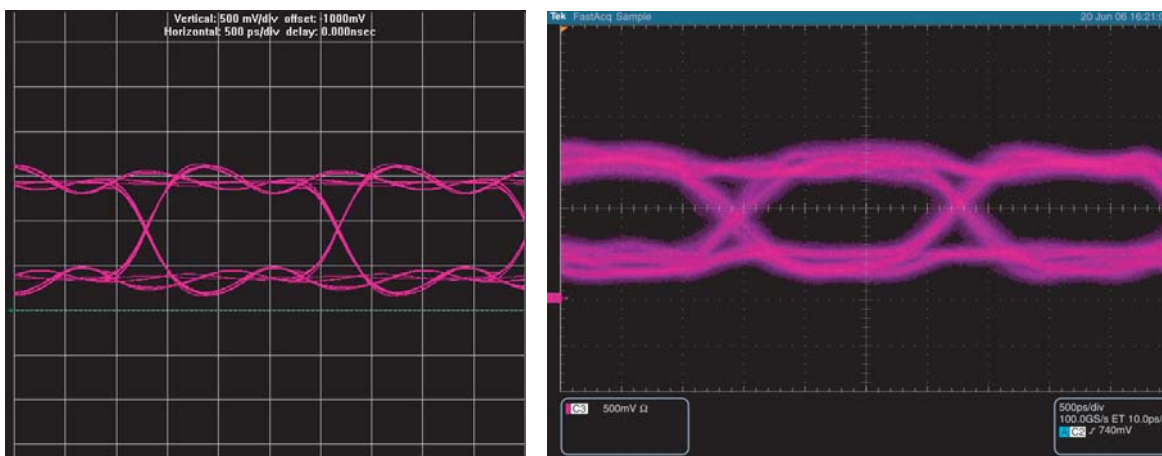

Table 5-11 summarizes the comparison between the simulation and board measurements of the signal seen at the DDR2 SDRAM of a dual-DIMM with slot 1 populated by a memory interface using a different ODT setting.

**Table 5-11. Comparison of the Signal at the Memory of a Dual-DIMM Interface With Only Slot 1 Populated and a Different ODT Setting**

Type	Eye Width (ns)	Eye Height (V)	Overshoot (V)	Undershoot (V)	Rising Edge Rate (V/ns)	Falling Edge Rate (V/ns)
<b>ODT Setting of 75 <math>\Omega</math></b>						
Simulation	1.68	0.91	NA	NA	1.88	1.88
Measurements	1.28	0.57	NA	NA	1.54	1.38
<b>ODT Setting of 150 <math>\Omega</math></b>						
Simulation	1.68	0.97	0.06	NA	2.67	2.13
Measurements	1.30	0.63	0.22	0.20	1.74	1.82

## Write to Memory in Slot 2 Using an ODT Setting of 75 $\Omega$ With One Slot Populated

Figure 5-22 shows the simulation and measurements result of the signal seen at the memory when the FPGA is writing to the memory with an ODT setting of 75  $\Omega$  and using a 25- $\Omega$  OCT drive strength setting on the FPGA.

**Figure 5-22. HyperLynx Simulation and Board Measurement of the Signal at the Memory in Slot 2 with Slot 1 Unpopulated**

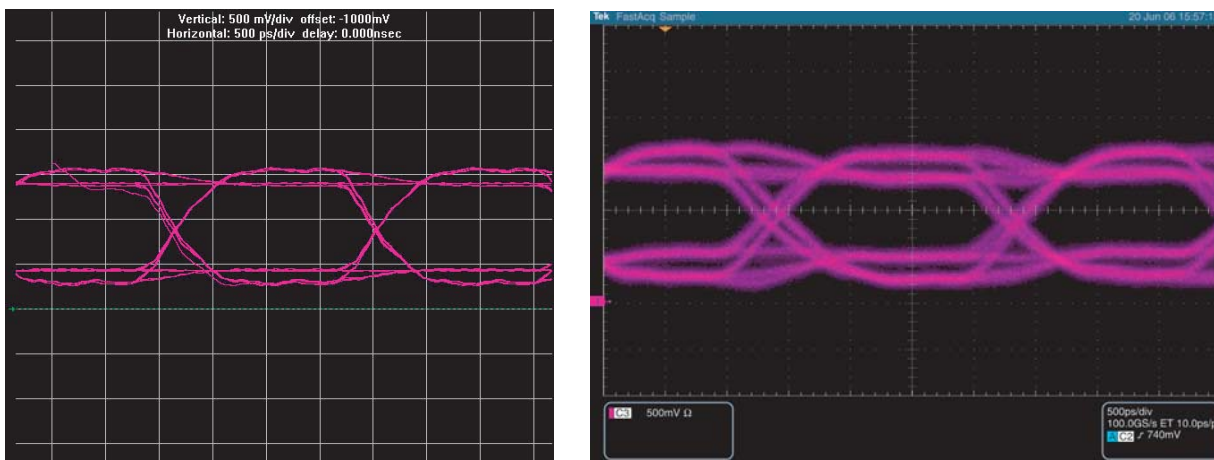

Table 5-12 summarizes the comparison of the signal at the memory of a dual-DIMM memory interface with either slot 1 or slot 2 populated using a double parallel termination using an ODT setting of 75  $\Omega$  with a memory-side series resistor with a 25- $\Omega$  OCT strength setting on the FPGA.

**Table 5-12. Comparison of Signal at the Memory of a Dual-DIMM Interface With Only Slot 2 Populated and a Different ODT Setting**

Type	Eye Width (ns)	Eye Height (V)	Overshoot (V)	Undershoot (V)	Rising Edge Rate (V/ns)	Falling Edge Rate (V/ns)
<b>ODT Setting of 75 <math>\Omega</math></b>						
Simulation	1.68	0.89	NA	NA	1.82	1.93
Measurements	1.29	0.59	NA	NA	1.60	1.29
<b>ODT Setting of 150 <math>\Omega</math></b>						
Simulation	1.69	0.94	0.07	0.02	1.88	2.29
Measurements	1.28	0.68	0.24	0.20	1.60	1.60

## Write to Memory in Slot 1 Using an ODT Setting of 150 $\Omega$ With Both Slots Populated

Figure 5-23 shows the HyperLynx simulation and board measurement of the signal at the memory in slot 1 of a double parallel termination using an ODT setting of 150  $\Omega$  on Slot 2 with a memory-side series resistor transmission line when the FPGA is writing to the memory with a 25- $\Omega$  OCT drive strength setting.

**Figure 5-23. HyperLynx Simulation and Board Measurement of the Signal at the Memory in Slot 1 With Both Slots Populated**

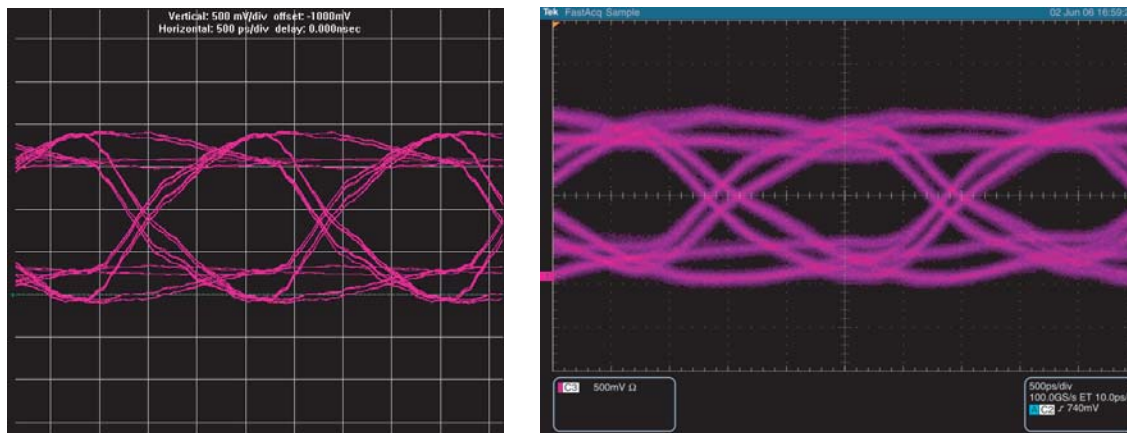

Table 5-13 summarizes the comparison between the simulation and board measurements of the signal seen at the memory in slot 1 of a dual-DIMM memory interface with both slots populated using a double parallel termination using a different ODT setting on Slot 2 with a memory-side series resistor with a 25- $\Omega$  OCT strength setting on the FPGA.

**Table 5-13. Comparison of Signal at the Memory of a Dual-DIMM Interface with Both Slots Populated and a Different ODT Setting on Slot 2**

Type	Eye Width (ns)	Eye Height (V)	Overshoot (V)	Undershoot (V)	Rising Edge Rate (V/ns)	Falling Edge Rate (V/ns)
<b>ODT Setting of 150 <math>\Omega</math></b>						
Simulation	1.60	1.18	0.02	NA	1.71	1.71
Measurements	0.89	0.78	0.13	0.17	1.19	1.32
<b>ODT Setting of 75 <math>\Omega</math></b>						
Simulation	1.60	1.18	0.02	NA	1.71	1.71
Measurements	0.97	0.77	0.05	0.04	1.25	1.25

## Write to Memory in Slot 2 Using an ODT Setting of 150 Ω With Both Slots Populated

Figure 5-24 shows the HyperLynx simulation and board measurement of the signal at the memory in slot 2 of a double parallel termination using an ODT setting of 150 Ω on slot 1 with a memory-side series resistor transmission line when the FPGA is writing to the memory with a 25-Ω OCT drive strength setting.

**Figure 5-24. HyperLynx Simulation and Board Measurements of the Signal at the Memory in Slot 2 with Both Slots Populated**

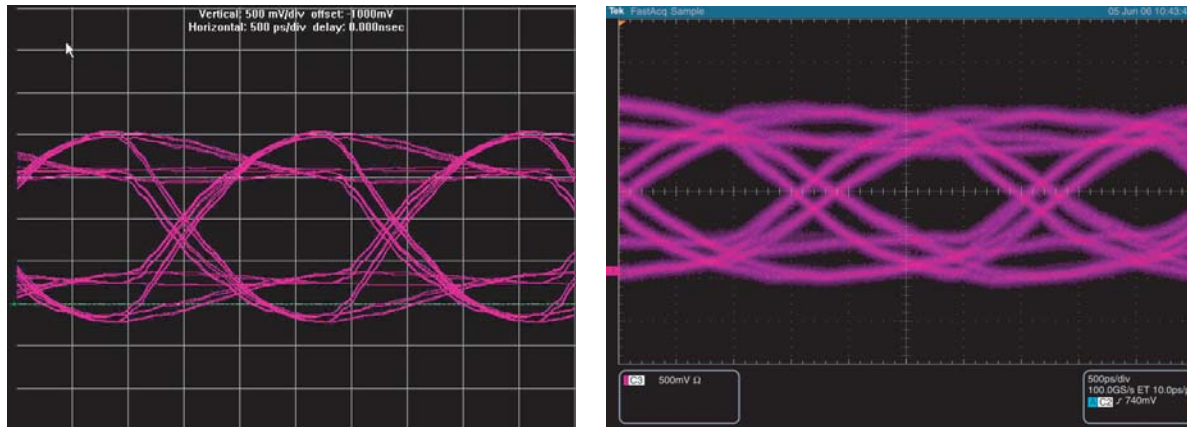

Table 5-14 summarizes the comparison between the simulation and board measurements of the signal seen at the memory of a dual-DIMM memory interface with both slots populated using a double parallel termination using a different ODT setting on Slot 1 with a memory-side series resistor with a 25-Ω OCT strength setting on the FPGA.

**Table 5-14. Comparison of the Signal at the Memory of a Dual-DIMM Interface With Both Slots Populated and a Different ODT Setting on Slot 1**

Type	Eye Width (ns)	Eye Height (V)	Overshoot (V)	Undershoot (V)	Rising Edge Rate (V/ns)	Falling Edge Rate (V/ns)
<b>ODT Setting of 150 Ω</b>						
Simulation	1.45	1.11	0.19	0.17	1.43	2.21
Measurements	0.71	0.81	0.12	0.20	0.93	1.00
<b>ODT Setting of 75 Ω</b>						
Simulation	1.60	1.16	0.10	0.08	1.68	1.60
Measurements	1.10	0.85	0.16	0.19	1.11	1.25

## Read from Memory in Slot 1 Using an ODT Setting of 150 $\Omega$ on Slot 2 with Both Slots Populated

Figure 5-25 shows the HyperLynx simulation and board measurement of the signal at the FPGA of a double parallel termination using an external parallel resistor on the FPGA side with a memory-side series resistor and an ODT setting of 150  $\Omega$  with a full drive strength setting on the memory.

**Figure 5-25. HyperLynx Simulation and Board Measurement of the Signal at the FPGA When Reading From Slot 1 With Both Slots Populated (1)**

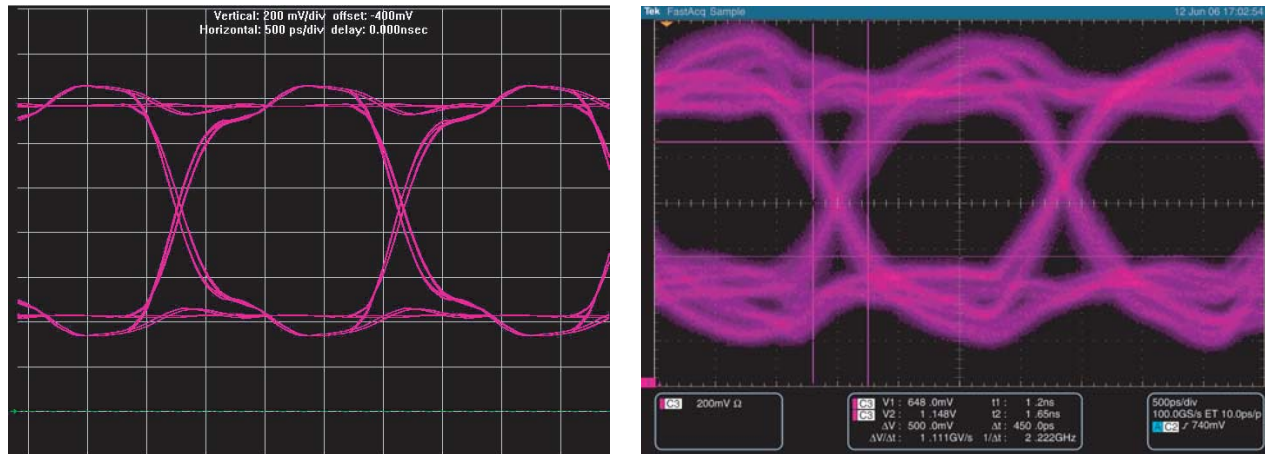

**Note to Figure 5-25:**

(1) The vertical scale used for the simulation and measurement is set to 200 mV per division.

Table 5-15 summarizes the comparison between the simulation and board measurements of the signal seen at the FPGA of a dual-DIMM memory interface with both slots populated using a different ODT setting on Slot 2.

**Table 5-15. Comparison of Signal at the FPGA of a Dual-DIMM Interface With Both Slots Populated and a Different ODT Setting on Slot 2**

Type	Eye Width (ns)	Eye Height (V)	Overshoot (V)	Undershoot (V)	Rise Edge Rate (V/ns)	Falling Edge Rate (V/ns)
<b>ODT Setting of 150 <math>\Omega</math></b>						
Simulation	1.68	0.77	NA	NA	1.88	1.88
Measurements	0.76	0.55	NA	NA	1.11	1.14
<b>ODT Setting of 75 <math>\Omega</math></b>						
Simulation	1.74	0.87	NA	NA	1.91	1.88
Measurements	0.86	0.59	NA	NA	1.11	1.09

## Read From Memory in Slot 2 Using an ODT Setting of 150 Ω on Slot 1 With Both Slots Populated

Figure 5-26 shows the HyperLynx simulation board measurement of the signal seen at the FPGA of a double parallel termination using an external parallel resistor on the FPGA side with memory-side series resistor and an ODT setting of 150 Ω with a full drive strength setting on the memory.

**Figure 5-26. HyperLynx Simulation Board Measurement of the Signal at the FPGA When Reading From Slot 2 With Both Slots Populated (1)**

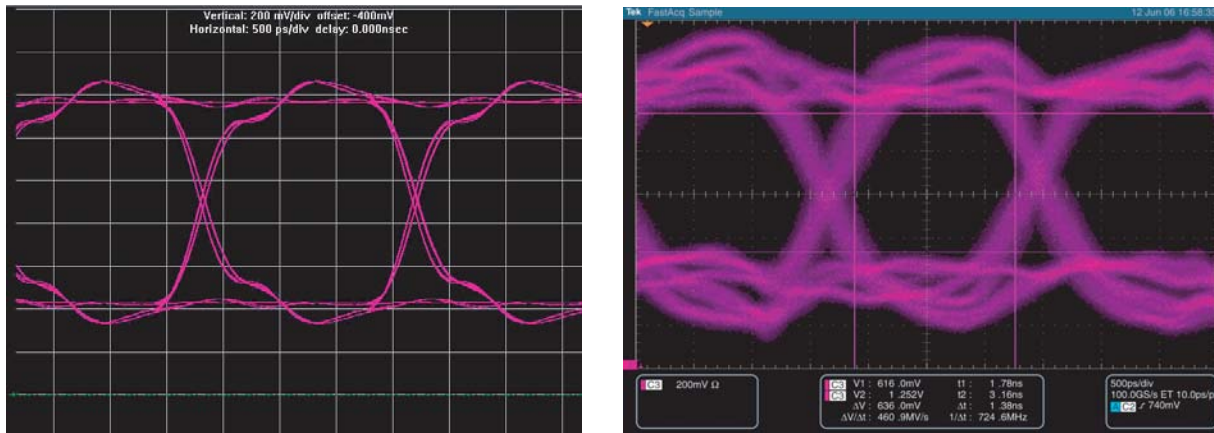

**Note to Figure 5-26:**

(1) The vertical scale used for the simulation and measurement is set to 200 mV per division.

Table 5-16 summarizes the comparison between the simulation and board measurements of the signal seen at the FPGA of a dual-DIMM memory interface with both slots populated using a different ODT setting on Slot 1.

**Table 5-16. Comparison of Signal at the FPGA of a Dual-DIMM Interface With Both Slots Populated and a Different ODT Setting on Slot 1**

Type	Eye Width (ns)	Eye Height (V)	Overshoot (V)	Undershoot (V)	Rising Edge Rate (V/ns)	Falling Edge Rate (V/ns)
<b>ODT Setting of 150 Ω</b>						
Simulation	1.70	0.74	NA	NA	1.91	1.64
Measurements	0.74	0.64	NA	NA	1.14	1.14
<b>ODT Setting of 75 Ω</b>						
Simulation	1.70	0.81	NA	NA	1.72	1.99
Measurements	0.87	0.59	NA	NA	1.09	1.14

## FPGA OCT Features

Many FPGA devices offer OCT. Depending on the chosen device family, series (output), parallel (input) or dynamic (bidirectional) OCT may be supported.

-  For more information specific to your device family, refer to the respective I/O features chapter in the relevant device handbook.

Use series OCT in place of the near-end series terminator typically used in both Class I or Class II termination schemes that both DDR2 and DDR3 type interfaces use.

Use parallel OCT in place of the far-end parallel termination typically used in Class I termination schemes on unidirectional input only interfaces. For example, QDR-II type interfaces, when the FPGA is at the far end.

Use dynamic OCT in place of both the series and parallel termination at the FPGA end of the line. Typically use dynamic OCT for DQ and DQS signals in both DDR2 and DDR3 type interfaces. As the parallel termination is dynamically disabled during writes, the FPGA driver only ever drives into a Class I transmission line. When combined with dynamic ODT at the memory, a truly dynamic Class I termination scheme exists where both reads and writes are always fully Class I terminated in each direction. Hence, you can use a fully dynamic bidirectional Class I termination scheme instead of a static discretely terminated Class II topology, which saves power, printed circuit board (PCB) real estate, and component cost.

### Arria V, Cyclone V, Stratix III, Stratix IV, and Stratix V Devices

Arria® V, Cyclone® V, Stratix III, Stratix IV, and Stratix V devices feature full dynamic OCT termination capability, Altera advise that you use this feature combined with the SDRAM ODT to simplify PCB layout and save power.

### Arria II GX Devices

Arria II GX devices do not support dynamic OCT. Altera recommends that you use series OCT with SDRAM ODT. Use parallel discrete termination at the FPGA end of the line when necessary,

-  For more information, refer to the *DDR2 and DDR3 SDRAM Board Design Guidelines* chapter.

## Document Revision History

Table 5-17 lists the revision history for this document.

**Table 5-17. Document Revision History**

<b>Date</b>	<b>Version</b>	<b>Changes</b>
November 2011	4.0	Added Arria V and Cyclone V information.
June 2011	3.0	Added Stratix V information.
December 2010	2.1	Maintenance update.
July 2010	2.0	Updated Arria II GX information.
April 2010	1.0	Initial release.