

Cyclone[®] IV Device Family Pin Connection Guidelines

PCG-01008- 1.2

© 2010 Altera Corporation. All rights reserved. Altera, The Programmable Solutions Company, the stylized Altera logo, specific device designations, and all other words and logos that are identified as trademarks and/or service marks are, unless noted otherwise, the trademarks and service marks of Altera Corporation in the U.S. and other countries. All other product or service names are the property of their respective holders. Altera products are protected under numerous U.S. and foreign patents and pending applications, maskwork rights, and copyrights. Altera warrants performance of its semiconductor products to current specifications in accordance with Altera's standard warranty, but reserves the right to make changes to any products and services at any time without notice. Altera assumes no responsibility or liability arising out of the application or use of any information, product, or service described herein except as expressly agreed to in writing by Altera. Altera customers are advised to obtain the latest version of device specifications before relying on any published information and before placing orders for products or services.

The pin connection guidelines are considered preliminary. These pin connection guidelines should only be used as a recommendation, not as a specification. The use of the pin connection guidelines for any particular design should be verified for device operation, with the datasheet and Altera.

PLEASE REVIEW THE FOLLOWING TERMS AND CONDITIONS CAREFULLY BEFORE USING THE PIN CONNECTION GUIDELINES ("GUIDELINES") PROVIDED TO YOU. BY USING THESE GUIDELINES, YOU INDICATE YOUR ACCEPTANCE OF SUCH TERMS AND CONDITIONS, WHICH CONSTITUTE THE LICENSE AGREEMENT ("AGREEMENT") BETWEEN YOU AND ALTERA CORPORATION ("ALTERA"). IF YOU DO NOT AGREE WITH ANY OF THESE TERMS AND CONDITIONS, DO NOT DOWNLOAD, COPY, INSTALL, OR USE THESE GUIDELINES.

1. Subject to the terms and conditions of this Agreement, Altera grants to you the use of this pin connection guideline to determine the pin connections of an Altera[®] programmable logic device-based design. You may not use this pin connection guideline for any other purpose.
2. Altera does not guarantee or imply the reliability, or serviceability, of the pin connection guidelines or other items provided as part of these guidelines. The files contained herein are provided 'AS IS'. ALTERA DISCLAIMS ALL WARRANTIES, EXPRESS OR IMPLIED, INCLUDING THE IMPLIED WARRANTIES OF MERCHANTABILITY AND FITNESS FOR A PARTICULAR PURPOSE.
3. In no event shall the aggregate liability of Altera relating to this Agreement or the subject matter hereof under any legal theory (whether in tort, contract, or otherwise), exceed One US Dollar (US\$1.00). In no event shall Altera be liable for any lost revenue, lost profits, or other consequential, indirect, or special damages caused by your use of these guidelines even if advised of the possibility of such damages.
4. This Agreement shall be governed by the laws of the State of California, without regard to conflict of law or choice of law principles. You agree to submit to the exclusive jurisdiction of the courts in the County of Santa Clara, State of California for the resolution of any dispute or claim arising out of or relating to this Agreement. The parties hereby agree that the party who is not the substantially prevailing party with respect to a dispute, claim, or controversy relating to this Agreement shall pay the costs actually incurred by the substantially prevailing party in relation to such dispute, claim, or controversy, including attorneys' fees.

BY DOWNLOADING OR USING THESE GUIDELINES, YOU ACKNOWLEDGE THAT YOU HAVE READ THIS AGREEMENT, UNDERSTAND IT, AND AGREE TO BE BOUND BY ITS TERMS AND CONDITIONS. YOU AND ALTERA FURTHER AGREE THAT IT IS THE COMPLETE AND EXCLUSIVE STATEMENT OF THE AGREEMENT BETWEEN YOU AND ALTERA, WHICH SUPERSEDES ANY PROPOSAL OR PRIOR AGREEMENT, ORAL OR WRITTEN, AND ANY OTHER COMMUNICATIONS BETWEEN YOU AND ALTERA RELATING TO THE SUBJECT MATTER OF THIS AGREEMENT.

Pin Connection Guidelines Agreement © 2010 Altera Corporation. All rights reserved.

Cyclone® IV Device Family Pin Connection Guidelines
PCG-01008- 1.2

Create a Quartus® II design, enter your device I/O assignments and compile the design. The Quartus II software will check your pin connections with respect to I/O assignment and placement rules to ensure proper device operation. These rules are dependent on device density, package, I/O assignments, voltage assignments, and other factors that are not fully described in this document or the device handbook.

Cyclone GX IV Devices Pin Name	Cyclone IV E Devices Pin Name	Pin Type (1st, 2nd, and 3rd Function)	Pin Description	Connection Guidelines
Clock and PLL Pins				
CLK[5, 7, 9, 11, 12, 14, 17, 19, 20, 22], DIFFCLK_0..9]n (Note 9) REFCLK[0..5]p (Note 22)	CLK[0,2,4,6,9,11,13,15], DIFFCLK_0..7]p (Note 9)	Clock, Input	Dedicated global clock input pins that can also be used for the positive terminal inputs for differential global clock input or user input pins. In Cyclone IV GX devices, some of these pins are optional high speed differential reference clock positive input.	Connect unused CLK or DIFFCLK pins to GND. See Note 12. In Cyclone IV GX devices, the pin should be AC-coupled if used as optional high speed differential reference clock input. Connect all unused pins either individually to GND through a 10-KΩ resistor or tie all unused pins together through a single 10-KΩ resistor. Ensure that the trace from the pins to the resistor(s) is as short as possible.
CLK[4, 6, 8, 10, 13, 15, 16, 18, 21, 23], DIFFCLK_0..9]n (Note 9) REFCLK[0..5]n (Note 22)	CLK[1,3,5,7,8,10,12,14], DIFFCLK_0..7]n (Note 9)	Clock, Input	Dedicated global clock input pins that can also be used for the negative terminal inputs for differential global clock input or user input pins. In Cyclone IV GX devices, some of these pins are optional high speed differential reference clock complement input.	Connect unused CLK or DIFFCLK pins to GND. See Note 12. In Cyclone IV GX devices, the pin should be AC-coupled if used as optional high speed differential reference clock input. Connect all unused pins either individually to GND through a 10-KΩ resistor or tie all unused pins together through a single 10-KΩ resistor. Ensure that the trace from the pins to the resistor(s) is as short as possible.
PLL[1,2,3,4,5,8]_CLKOUTp (Note 10)	PLL[1..4]_CLKOUTp (Note 10)	I/O, Output	Optional positive terminal for external clock outputs from PLL [1..8] in Cyclone IV GX devices. Optional positive terminal for external clock outputs from PLL [1..4] in Cyclone IV E devices. Each pin can be assigned to single-ended or differential I/O standards if it is being fed by a PLL output.	When not using this pin as a clock output, this pin may be used as a user I/O. When not using these pins, connect them as defined in Quartus II software. See Note 12.
PLL[1,2,3,4,5,8]_CLKOUTn (Note 10)	PLL[1..4]_CLKOUTn (Note 10)	I/O, Output	Optional negative terminal for external clock outputs from PLL [1..8] in Cyclone IV GX devices. Optional negative terminal for external clock outputs from PLL [1..4] in Cyclone IV E devices. Each pin can be assigned to single-ended or differential I/O standards if it is being fed by a PLL output.	When not using this pin as a clock output, this pin may be used as a user I/O. When not using these pins, connect them as defined in Quartus II software. See Note 12.
Configuration/ JTAG Pins				
MSEL[0..3]	MSEL[0..3]	Input	Configuration input pins that set the Cyclone IV device configuration scheme. The smaller Cyclone IV GX devices like EP4CGX15, EP4CGX22, and EP4CGX30 (except F484 package) do not have the MSEL[3] pin. Some of the smaller Cyclone IV E devices or package options do not support AP configuration scheme and do not have the MSEL[3] pin.	These pins are internally connected through a 9-KΩ resistor to GND. Do not leave these pins floating. When these pins are unused, connect them to GND. Depending on the configuration scheme used, these pins should be tied to VCCA or GND. Refer to the "Configuration and Remote System Upgrades in Cyclone IV Devices" chapter in the Cyclone IV Handbook. If only JTAG configuration is used, connect these pins to GND.
nCE	nCE	Input	Dedicated active-low chip enable. When nCE is low, the device is enabled. When nCE is high, the device is disabled.	In a multi-device configuration, nCE of the first device is tied low while its nCEO pin drives the nCE of the next device in the chain. In single device configuration and JTAG programming, nCE should be connected to GND.
nCONFIG	nCONFIG	Input	Dedicated configuration control input. Pulling this pin low during user-mode will cause the FPGA to lose its configuration data, enter a reset state, and tri-state all I/O pins. Returning this pin to a logic high level will initiate reconfiguration.	If you are using PS configuration scheme with a download cable, connect this pin through a 10-KΩ resistor to VCCA. For other configuration schemes, if this pin is not used, this pin must be connected directly or through a 10-KΩ resistor to VCCIO.
CONF_DONE	CONF_DONE	Bidirectional (open-drain)	This is a dedicated configuration status pin. As a status output, the CONF_DONE pin drives low before and during configuration. Once all configuration data is received without error and the initialization cycle starts, CONF_DONE is released. As a status input, CONF_DONE goes high after all data is received. Then the device initializes and enters user mode.	This pin is not available as a user I/O pin. CONF_DONE should be pulled high by an external 10-KΩ pull-up resistor.
nCEO	nCEO	I/O, Output (open-drain)	Output that drives low when device configuration is complete. This pin can be used as a regular I/O if not used for device configuration.	When not using this pin, you can leave it unconnected. During multi-device configuration, this pin feeds the nCE pin of a subsequent device. In this case, tie the 10-KΩ pull-up resistor to an acceptable voltage for all devices in the chain which satisfies the input voltage of the receiving device. During single device configuration, this pin can be used as a regular I/O.
nSTATUS	nSTATUS	Bidirectional (open-drain)	This is a dedicated configuration status pin. The FPGA drives nSTATUS low immediately after power-up and releases it after POR time. As a status output, the nSTATUS is pulled low if an error occurs during configuration. As a status input, the device enters an error state when nSTATUS is driven low by an external source during configuration or initialization.	This pin is not available as a user I/O pin. nSTATUS should be pulled high by an external 10-KΩ pull-up resistor.
TCK	TCK	Input	Dedicated JTAG test clock input pin.	Connect this pin to a 1-KΩ pull-down resistor to GND. To disable the JTAG circuitry connect TCK to GND.
TMS	TMS	Input	Dedicated JTAG test mode select input pin.	Connect this pin to a 1-KΩ to 10-KΩ pull-up resistor to VCCA. (Note 13) To disable the JTAG circuitry connect TMS to VCCA.
TDI	TDI	Input	Dedicated JTAG test data input pin.	Connect this pin to a 1-KΩ to 10-KΩ pull-up resistor to VCCA. (Note 13) To disable the JTAG circuitry connect TDI to VCCA.
TDO	TDO	Output	Dedicated JTAG test data output pin.	If the TDO pin is not used, leave this pin unconnected.
nCSO	FLASH_nCE, nCSO	I/O, Output (AS, AP Note 18)	This pin functions as FLASH_nCE in AP (Note 18) mode, and nCSO in AS mode. nCSO: Output control signal from the FPGA to the serial configuration device in AS mode that enables the configuration device. FLASH_nCE: Output control signal from the FPGA to the parallel flash in AP mode that enables the flash device.	When not programming the device in AS mode, nCSO is not used. When not programming the device in AP mode, FLASH_nCE is not used. If the pin is not used as an I/O, you should leave the pin unconnected.
DATA1, ASDO	DATA1, ASDO	Input (FPP) Output (AS) Bidirectional open-drain (AP Note 18)	This pin functions as DATA1 in PS and FPP modes, and as ASDO in AS mode. DATA1: Data input in non-AS mode. Byte-wide configuration data is presented to the target device on DATA[0..7]. In PS configuration scheme, DATA1 functions as user I/O pin during configuration, which means it is tri-stated. After FPP configuration, DATA1 is available as a user I/O pin and the state of this pin depends on the Dual-Purpose Pin settings. ASDO: Control signal from the FPGA to the serial configuration device in AS mode used to read out configuration data.	When not programming the device in AS mode, this pin is available as a user I/O pin. If the pin is not used as an I/O, then you should leave the pin unconnected.
DATA[2..7]	DATA[2..7]	Input (FPP) Bidirectional (AP Note 18)	Data inputs. Byte-wide or word-wide configuration data is presented to the target device on DATA[0..7] or DATA[0..15] respectively. In AS or PS configuration scheme, they function as user I/O pins during configuration, which means they are tri-stated. After FPP configuration, DATA [2..7] are available as user I/O pins and the state of these pins depends on the Dual-Purpose Pin settings.	When not programming the device in AS mode, these pins are available as a user I/O pins. If the pin is not used as an I/O you should leave the pin unconnected.

Cyclone® IV Device Family Pin Connection Guidelines
PCG-01008-1.2

Create a Quartus® II design, enter your device I/O assignments and compile the design. The Quartus II software will check your pin connections with respect to I/O assignment and placement rules to ensure proper device operation. These rules are dependent on device density, package, I/O assignments, voltage assignments, and other factors that are not fully described in this document or the device handbook.

Cyclone GX IV Devices Pin Name	Cyclone IV E Devices Pin Name	Pin Type (1st, 2nd, and 3rd Function)	Pin Description	Connection Guidelines
NA	DATA[8..15]	Bidirectional (AP Note 18)	In the PS, FPP, or AS configuration scheme, they function as user I/O pins during configuration, which means they are tri-stated. After AP configuration, DATA[8..15] are dedicated bidirectional pins with optional user control.	When not programming the device in AP mode, these pins are available as user I/O pins. If these pins are not used as I/Os, then it is recommended to leave the pin unconnected.
NA	PADD[0..23]	Output (AP Note 18)	24-bit address bus from the Cyclone IV E device to the parallel flash in AP mode.	When not programming the device in AP mode, these pins are available as user I/O pins. If these pins are not used as I/Os, then it is recommended to leave the pin unconnected.
NA	nRESET	Output (AP Note 18)	Active-low reset output. Driving the nRESET pin low resets the parallel flash.	When not programming the device in AP mode, nRESET is not used and is available as a user I/O pin. If the pin is not used as an I/O then it is recommended to leave the pin unconnected.
NA	nAVD	Output (AP Note 18)	Active-low address valid output. Driving the nAVD pin low during read or write operation indicates to the parallel flash that valid address is present on the PADD[0..23] address bus.	When not programming the device in AP mode, nAVD is not used and is available as a user I/O pin. If the pin is not used as an I/O then it is recommended to leave the pin unconnected.
NA	nOE	Output (AP Note 18)	Active-low output enable to the parallel flash. Driving the nOE pin low during read operation enables the parallel flash outputs (DATA[0..15] and RDY).	When not programming the device in AP mode, nOE is not used and is available as a user I/O pin. If the pin is not used as an I/O then it is recommended to leave the pin unconnected.
NA	nWE	Output (AP Note 18)	Active-low write enable to the parallel flash. Driving the nWE pin low during write operation indicates to the parallel flash that data on the DATA[0..15] bus is valid.	When not programming the device in AP mode, nWE is not used and is available as a user I/O pin. If the pin is not used as an I/O then it is recommended to leave the pin unconnected.
DCLK	DCLK	Input (PS, FPP) Output (AS, AP Note 18)	Dedicated configuration clock pin. In PS and FPP configuration, DCLK is used to clock configuration data from an external source into the FPGA. In AS and AP (Note 18) modes, DCLK is an output from the FPGA that provides timing for the configuration interface.	Do not leave this pin floating. Drive this pin either high or low.
CRC_ERROR	CRC_ERROR (Note 19 and 21)	I/O, Output	Active high signal that indicates that the error detection circuit has detected errors in the configuration SRAM bits. This pin is optional and is used when the CRC error detection circuit is enabled. This pin can be used as regular I/O if not used for CRC error detection. The CRC_ERROR pin is a dedicated output by default. Optionally, you can enable the CRC_ERROR pin as an open-drain output in the Device & Pin option dialog box in the Quartus II software.	When using this pin, connect it to an external 10-K Ω pull-up resistor to an acceptable voltage for all devices in the chain that satisfies the input voltage of the receiving device. When not using this pin, it can be left floating.
DEV_CLRn	DEV_CLRn	I/O (when option off), Input (when option on)	Optional pin that allows designers to override all clears on all device registers. When this pin is driven low, all registers are cleared; when this pin is driven high, all registers behave as programmed. This pin is enabled by turning on the Enable device-wide reset (DEV_CLRn) option in the Quartus II software.	When the dedicated input DEV_CLRn is not used and this pin is not used as an I/O, tie this pin to GND.
DEV_OE	DEV_OE	I/O (when option off), Input (when option on)	Optional pin that allows designers to override all tri-states on the device. When this pin is driven low, all I/O pins are tri-stated; when this pin is driven high, all I/O pins behave as defined in the design. This pin is enabled by turning on the Enable device-wide output enable (DEV_OE) option in the Quartus II software.	When the dedicated input DEV_OE is not used and this pin is not used as an I/O, then you should tie this pin to GND.
DATA0	DATA0	Input (PS, FPP, AS) Bidirectional open-drain (AP Note 18)	Dedicated configuration data input pin. In serial configuration modes, bit-wide configuration data is received through this pin. After AS configuration, DATA0 is a dedicated input pin with optional user control. After PS or FPP configuration, DATA0 is available as a user I/O pin and the state of this pin depends on the Dual-Purpose Pin settings. After AP (Note 18) configuration, DATA0 is a dedicated bidirectional pin with optional user control.	If you are using a serial configuration device in AS configuration mode, you must connect a 25- Ω series resistor at the near end of the serial configuration device for the DATA0. When the dedicated input for DATA0 is not used and this pin is not used as an I/O, then you should leave this pin unconnected.
INIT_DONE	INIT_DONE	I/O, Output (open-drain)	This is a dual-purpose pin and can be used as an I/O pin when not enabled as INIT_DONE. When enabled, a transition from low to high at the pin indicates when the device has entered user mode. If the INIT_DONE output is enabled, the INIT_DONE pin cannot be used as a user I/O pin after configuration. This pin is enabled by turning on the Enable INIT_DONE output option in the Quartus II software.	When using this pin, connect it to an external 10-K Ω pull-up resistor to an acceptable voltage for all devices in the chain that satisfies the input voltage of the receiving device. When not using this pin, it can be left floating or tied to GND.
CLKUSR	CLKUSR	I/O, Input	Optional user-supplied clock input. Synchronizes the initialization of one or more devices. If this pin is not enabled for use as a user-supplied configuration clock, it can be used as a user I/O pin. This pin is enabled by turning on the Enable user-supplied start-up clock (CLKUSR) option in the Quartus II software.	If the CLKUSR pin is not used as a configuration clock input and the pin is not used as an I/O, then you should connect this pin to GND.
Differential I/O Pins				
DIFFIO_[R,T,B][0..72][p,n] (Note 14)	DIFFIO_[L,R,T,B][0..61][p,n] (Note 14)	I/O, TX/RX channel	Dual-purpose differential transmitter/receiver channels. These channels can be used for transmitting/receiving LVDS compatible signals. Pins with a "p" suffix carry the positive signal for the differential channel. Pins with an "n" suffix carry the negative signal for the differential channel. If not used for differential signaling, these pins are available as user I/O pins.	When these IO pins are not used, they can be tied to GND. See Note 12.
External Memory Interface Pins				
DQS[0..5][R,T,B]/CQ[0,1,3,5][R,T,B] #,DPCLK[0..17] (Note 15)	DQS[0..5][L,R,T,B]/CQ[1,3,5][L,R,T,B]#,DPCLK[0..11] (Note 15)	I/O, DQS/CQ, DPCLK	Dual-purpose DPCLK/DQS pins can connect to the global clock network for high-fanout control signals such as clocks, asynchronous clears, presets and clock enables. It can also be used as optional data strobe signal for use in external memory interfacing. These pins drive to dedicated DQS phase shift circuitry, which allows fine tune of the phase shift for input clocks or strobes to properly align clock edges needed to capture data.	When these IO pins are not used, they can be tied to GND. See Note 12.
NA	DQS[0..5][L,R,T,B]/CQ[1,3,5][L,R,T,B]#,CDPCLK[0..7] (Note 15)	I/O, DQS/CQ, CDPCLK	Dual-purpose CDPCLK/DQS pins can connect to the global clock network for high fan-out control signals such as clocks, asynchronous clears, presets, and clock enables. Only one of the two CDPCLK in each corner can feed the clock control block at a time. The other pin can be used as general-purpose I/O pin. The CDPCLK signals incur more delay to the clock block control because they are multiplexed before driving into the clock block control. It can also be used as optional data strobe signal for use in external memory interfacing. These pins drive to dedicated DQS phase shift circuitry, which allows fine tune of the phase shift for input clocks or strobes to properly align clock edges needed to capture data.	When these IO pins are not used, they can be tied to GND. See Note 12.

Cyclone® IV Device Family Pin Connection Guidelines
PCG-01008- 1.2

Create a Quartus® II design, enter your device I/O assignments and compile the design. The Quartus II software will check your pin connections with respect to I/O assignment and placement rules to ensure proper device operation. These rules are dependent on device density, package, I/O assignments, voltage assignments, and other factors that are not fully described in this document or the device handbook.

Cyclone GX IV Devices Pin Name	Cyclone IV E Devices Pin Name	Pin Type (1st, 2nd, and 3rd Function)	Pin Description	Connection Guidelines
DQ[0..5][R,T,B] (Note 15)	DQ[0..5][L,R,T,B] (Note 15)	I/O, DQ	Optional data signal for use in external memory interface.	When these IO pins are not used, they can be tied to GND. See Note 12.
DM[0..5][R,T,B]/BWS#[0..5][R,T,B]	DM[0..5][L,R,B,T][0..1]/BWS#[0..5][L,R,T,B]	I/O, DM/BWS#	The data mask pins are only required when writing to DDR SDRAM and DDR2 SDRAM devices. QDRII SRAM devices use the BWS signal to select the byte to be written into memory. A low signal on the DM/BWS# pin indicates that the write is valid. Driving the DM/BWS# pin high results in the memory masking the DQ signals.	When these IO pins are not used, they can be tied to GND. See Note 12.
Reference Pins				
RUP[2..4]	RUP[1..4]	I/O, Input	Reference pins for on-chip termination (OCT) block in I/O banks 4, 5, and 7 in Cyclone IV GX devices. Reference pins for OCT block in I/O banks 2, 4, 5, and 7 in Cyclone IV E devices. The external precision resistor RUP must be connected to the designated RUP pin within the same bank when used. If the RUP pin is not used, this pin can function as a regular I/O pin.	When using OCT tie these pins to the required banks VCCIO through either a 25 Ω or 50 Ω resistor, depending on the desired I/O standard. When the device does not use this dedicated input for the external precision resistor or as an I/O, it is recommended that the pin be connected to VCCIO of the bank in which the RUP pin resides or GND.
RDN[2..4]	RDN[1..4]	I/O, Input	Reference pins for on-chip termination (OCT) block in I/O banks 4, 5, and 7 in Cyclone IV GX devices. Reference pins for OCT block in I/O banks 2, 4, 5, and 7 in Cyclone IV E devices. The external precision resistor RDN must be connected to the designated RDN pin within the same bank when used. If the RDN pin is not used, this pin can function as a regular I/O pin.	When using OCT tie these pins to GND through either a 25 Ω or 50 Ω resistor depending on the desired I/O standard. When the device does not use this dedicated input for the external precision resistor or as an I/O, it is recommended that the pin be connected to GND.
NC	NC	No Connect	Do not drive signals into these pins.	When designing for device migration, these pins may be connected to power, ground, or a signal trace depending on the pin assignment of the devices selected for migration. However, if device migration is not a concern, leave these pins floating.
Supply Pins (See Notes 16 and 17)				
VCCINT	VCCINT	Power	These are internal logic array voltage supply pins.	In Cyclone IV GX devices, all VCCINT pins must be connected to a 1.2 V supply. Can share VCCD_PLL and VCCL_GXB with VCCINT with proper isolation filters. Decoupling depends on the design decoupling requirements of the specific board. See Notes 3 and 5. In Cyclone IV E devices, all VCCINT pins must be connected to either a 1.0V supply or a 1.2 V supply. Cyclone IV E devices with VCCINT 1.0V, and Cyclone IV E devices with VCCINT 1.2V, have different ordering codes (Note 21). Can share VCCD_PLL with VCCINT with a proper isolation filter. Decoupling depends on the design decoupling requirements of the specific board. See Notes 3 and 5.
VCCD_PLL	VCCD_PLL[1..4]	Power	Digital power for PLLs[1..8] in Cyclone IV GX devices. Digital power for PLLs[1..4] in Cyclone IV E devices. The designer must power up these pins, even if the PLL is not used.	In Cyclone IV GX devices, you are required to connect these pins to 1.2 V, even if the PLL is not used. With a proper isolation filter these pins can be sourced from the same regulator as VCCINT and VCCL_GXB. Use an isolated switching power supply with ± 3 % maximum voltage ripple. (Note 11) Decoupling for these pins depends on the design decoupling requirements of the specific board. See Notes 3, 5, and 8. In Cyclone IV E devices, you are required to connect these pins to either 1.0 V (if VCCINT 1.0 V) or 1.2 V (if VCCINT 1.2 V), even if the PLL is not used. Cyclone IV E devices with VCCINT 1.0 V, and Cyclone IV E devices with VCCINT 1.2 V, have different ordering codes (Note 21). With a proper isolation filter these pins can be sourced from the same regulator as VCCINT. Use an isolated switching power supply with ± 3 % maximum voltage ripple. (Note 11) Decoupling for these pins depends on the design decoupling requirements of the specific board. See Notes 3, 5, and 8.
VCCA	VCCA[1..4]	Power	Analog power for PLLs[1..8] for Cyclone IV GX devices. Analog power for PLLs[1..4] for Cyclone IV E devices. All VCCA pins must be powered and all VCCA pins must be powered up and powered down at the same time even if not all the PLLs are used. Designer is advised to keep this pin isolated from other VCC pins for better jitter performance.	You are required to connect these pins to 2.5 V, even if the PLL is not used. Use an isolated linear or switching power supply with ± 3 % maximum voltage ripple. (Note 11) It is advised to keep this pin isolated from other VCC for better jitter performance. In Cyclone IV GX devices, these pins can share the same regulator as VCCA_GXB and VCCH_GXB with a proper isolation filter. Decoupling for these pins depends on the design decoupling requirements of the specific board. See Notes 3, 5, 6, and 8.
VCCIO[3..9]	VCCIO[1..8]	Power	These are I/O supply voltage pins for banks 3 through 9 in Cyclone IV GX devices. These are I/O supply voltage pins for banks 1 through 8 for Cyclone IV E devices. Each bank can support a different voltage level. VCCIO supplies power to the input and output buffers for all I/O standards.	In Cyclone IV GX devices, connect VCCIO pins on banks 4, 5, 6, 7, and 8 to 1.2 V/ 1.5 V/ 1.8 V/ 2.5 V/ 3.0 V/ 3.3 V supplies, depending on the I/O standard connected to the specified bank. I/O banks 3, 8, and 9 contain configuration pins. VCCIO pins on banks 3 and 9 support only 1.5 V/ 1.8 V/ 2.5 V/ 3.0 V/ 3.3 V. If FPP configuration is used, connect VCCIO pins on bank 8 to similar voltage level as banks 3 and 9. When these pins require 2.5 V, can share VCCH_GXB, VCCA_GXB, VCCA, and/or VCC_CLKIN with a common 2.5 V supply with proper isolation filters. See Notes 3 and 5. In Cyclone IV E devices, connect these pins to 1.2 V, 1.5 V, 1.8 V, 2.5 V, 3.0 V, or 3.3 V supplies, depending on the I/O standard assigned to the I/O bank. Decoupling depends on the design decoupling requirements of the specific board. See Notes 3 and 5.
VCC_CLKIN[3,8]	NA	Power	Differential clock input power supply for banks 3 and 8.	These pins can be tied to the same 2.5 V plane as VCCA, but only if each of these supplies require 2.5 V sources. Decoupling for these pins depends on the design decoupling requirements of the specific board. See Notes 2 and 3.
GND	GND	Ground	Device ground pins.	All GND pins should be connected to the board GND plane.
NA	GND_A[1..4]	Ground	Ground for PLLs[1..4] and other analog circuits in the device.	The designer can consider connecting the GND_A pins to the GND plane without isolating the analog ground plane on the board provided the digital GND plane(s) are stable, quiet, and with no ground bounce effect.
VREFB[3..8][N][0..2]	VREFB[1..8][N][0..2]	I/O	Input reference voltage for each I/O bank. If a bank uses a voltage-referenced I/O standard, then these pins are used as the voltage-reference pins for the bank. If voltage reference I/O standards are not used in the bank, the VREF pins are available as user I/O pins.	If VREF pins are not used, designers should connect them to either the VCCIO in the bank in which the pin resides or GND. Decoupling depends on the design decoupling requirements of the specific board. See Note 3.

Cyclone® IV Device Family Pin Connection Guidelines
PCG-01008- 1.2

Create a Quartus® II design, enter your device I/O assignments and compile the design. The Quartus II software will check your pin connections with respect to I/O assignment and placement rules to ensure proper device operation. These rules are dependent on device density, package, I/O assignments, voltage assignments, and other factors that are not fully described in this document or the device handbook.

Cyclone GX IV Devices Pin Name	Cyclone IV E Devices Pin Name	Pin Type (1st, 2nd, and 3rd Function)	Pin Description	Connection Guidelines
Transceiver Pins (See Notes 16 and 17)				
VCCL_GXB	NA	Power	Supplies power to the transceiver PMA TX, PMA RX and clocking.	Connect VCCL_GXB to a 1.2 V supply. With a proper isolation filter these pins can be sourced from the same regulator as VCCINT and VCCD_PLL. Use an isolated switching power supply with $\pm 3\%$ maximum voltage ripple. (Note 11) Decoupling for these pins depends on the design decoupling requirements of the specific board design. See Notes 3, 5, 6, and 23.
VCCH_GXB	NA	Power	Supplies power to the transceiver PMA output (TX) buffer.	Connect VCCH_GXB to a 2.5 V supply. These pins can be tied to the same 2.5 V plane as VCCA_GXB. Use an isolated linear or switching power supply with $\pm 3\%$ maximum voltage ripple. (Note 11) These pins may be sourced from the same regulator as VCCA with a proper isolation filter. Decoupling for these pins depends on the design decoupling requirements of the specific board design. See Notes 3, 5, 6, and 23.
VCCA_GXB	NA	Power	Supplies power to the transceiver PMA regulator.	Connect VCCA_GXB to a 2.5 V supply. These pins may be tied to the same 2.5 V plane as VCCH_GXB. Use an isolated linear or switching power supply with $\pm 3\%$ maximum voltage ripple. (Note 11) These pins may be sourced from the same linear regulator as VCCA with a proper isolation filter. Decoupling depends on the design decoupling requirements of the specific board design. See Notes 3, 5, 6, and 23.
GXB_RX[0..7]p (Note 7)	NA	Input	High speed positive differential receiver channels.	These pins may be AC-coupled or DC-coupled when used. (Note 4) Connect all unused GXB_RXp pins either individually to GND through a 10-K Ω resistor or tie all unused pins together through a single 10-K Ω resistor. Ensure that the trace from the pins to the resistor(s) is as short as possible. See Note 20.
GXB_RX[0..7]n (Note 7)	NA	Input	High speed negative differential receiver channels.	These pins may be AC-coupled or DC-coupled when used. (Note 4) Connect all unused GXB_RXn pins either individually to GND through a 10-K Ω resistor or tie all unused pins together through a single 10-K Ω resistor. Ensure that the trace from the pins to the resistor(s) is as short as possible. See Note 20.
GXB_TX[0..7]p (Note 7)	NA	Output	High speed positive differential transmitter channels.	Leave all unused GXB_TXp pins floating. See Note 20.
GXB_TX[0..7]n (Note 7)	NA	Output	High speed negative differential transmitter channels.	Leave all unused GXB_TXn pins floating. See Note 20.
RREF0	NA	Input	Reference resistor for transceiver.	This pin must be connected to a 2.00-K $\Omega \pm 1\%$ resistor to GND. In the PCB layout, the trace from this pin to the resistor needs to be routed so that it avoids any aggressor signals. See Note 23.

Notes:

- (1) In Cyclone IV GX devices, FPP configuration is supported in device package F484 of EP4CGX30, and all device packages of EP4CGX50, EP4CGX75, EP4CGX110, and EP4CGX150 devices. In Cyclone IV E devices, FPP configuration is supported in most devices, except the E144 package of Cyclone IV E devices.
- (2) VCC_CLKIN must be set to 2.5 V if the CLKIN is used as a transceiver refclk. The voltages of VCC_CLKIN for each device density is different. EP4CGX30 and smaller densities have VCC_CLKIN on Banks 3A and 8A that support 1.2 V/ 1.5 V/ 1.8 V/ 2.5 V/ 3.0 V/ 3.3 V voltages, and VCC_CLKIN on Banks 3B and 8B that support 2.5 V.
- (3) Capacitance values for the power supply decoupling capacitors should be selected after consideration of the amount of power needed to supply over the frequency of operation of the particular circuit being decoupled. A target impedance for the power plane should be calculated based on current draw and voltage drop requirements of the device/supply. The power plane should then be decoupled using the appropriate number of capacitors. On-board capacitors do not decouple higher than 100 MHz due to "Equivalent Series Inductance" of the mounting of the packages. Proper board design techniques such as interplane capacitance with low inductance should be considered for higher frequency decoupling. To assist in decoupling analysis, Altera's "Power Distribution Network (PDN) Design Tool" serves as an excellent decoupling analysis tool. The PDN design tool can be obtained at [Power Distribution Network Design Tool](#).
- (4) For AC-coupled links, the AC-coupling capacitor can be placed anywhere along the channel. PCI Express protocol requires the AC-coupling capacitor to be placed on the transmitter side of the interface that permits adapters to be plugged and unplugged.
- (5) Use the Cyclone IV Early Power Estimator to determine the current requirements for VCCINT and other power supplies.
- (6) These supplies may share power planes across multiple Cyclone IV devices.
- (7) Transceiver signals GXB_RX[0:7] and GXB_TX[0:7] are device specific.
- (8) Use separate power island for VCCA and VCCD_PLL. PLL power supply may originate from another plane on the board but must be isolated using a ferrite bead or other equivalent methods. If using a ferrite bead, choose an 0402 package with low DC resistance, higher current rating than the maximum steady state current for the supply it is connected to (VCCA or VCCD_PLL) and high impedance at 100 MHz.
- (9) The number of dedicated global clocks for each device density is different. Please refer to the "Clock Networks and PLLs in Cyclone IV Devices" chapter in the Cyclone IV Device Handbook.
- (10) The number of PLLs consisting of GPLLs and MPLLS for each device density is different. EP4CGX15 support 3 PLLs. EP4CGX22 and EP4CGX30 (except F484 package) support 4 PLLs. EP4CGX30 F484 package, EP4CGX50 and other larger Cyclone IV GX densities support 8 PLLs. EP4CE6 and EP4CE10 support 2 PLLs. EP4CE15 and other larger Cyclone IV E densities support 4 PLLs.
- (11) VCCH_GXB, VCCA_GXB, and VCCA may use a switching regulator with a voltage ripple of $\pm 3\%$ maximum. VCCD_PLL, and VCCL_GXB may use a switching power supply with a voltage ripple of $\pm 3\%$ maximum.
- (12) The unused pins must be connected as specified in the Quartus II software settings. The default Quartus II setting for unused pins is 'As inputs tri-stated with weak pull-up resistors', unless for specific pins that Quartus II software connects them to GND automatically. To change the setting, go to 'Assignments', then 'Device'. Click on 'Device & Pin options' dialog box and go to 'Unused Pins' tab. You may choose the desired setting from the 'Reserve all unused pins' drop down list.
- (13) You must follow specific requirements when interfacing Cyclone IV device with 2.5 V/3.0 V/3.3 V configuration voltage standards. All I/O inputs must maintain a maximum AC voltage of 4.1 V. Refer to Configuration and JTAG Pin I/O Requirements of the "Configuration and Remote System Upgrades in Cyclone IV Devices" chapter.
- (14) The differential TX/RX channels for each device density and package is different. Please refer to the "I/O Features in Cyclone IV Devices" chapter in the Cyclone IV Device Handbook.
- (15) For details about the DQ and DQS bus modes support in different device densities, refer to the "External Memory Interfaces in Cyclone IV Devices" chapter in the Cyclone IV Device Handbook.
- (16) Altera highly recommends using an independent PCB via for each independent power or ground ball on the package. Sharing power or ground pin vias on the PCB could lead to noise coupling into the device and result in reduced jitter performance.
- (17) Refer to Example 1 and Figure 1 on the "Power Regs" tab below for the minimum power supply regulator recommendations.
- (18) Configuration in AP mode is only supported in Cyclone IV E Devices and not in Cyclone IV GX Devices.
- (19) CRC error detection is only supported in Cyclone IV E devices with VCCINT 1.2 V, and not in Cyclone IV E devices with VCCINT 1.0 V.
- (20) The Quartus II *.pin file created after compiling the design project in Quartus II lists unused transceiver or clock input pins as GXB_GND* (unused GXB_RX, REFCLK), GXB_NC (unused GXB_TX) and GND+ (unused input clocks and PLLs). Verify that any pins listed as such in the Quartus II *.pin file are connected to the board as indicated in these recommendations.
- (21) There are two variants of Cyclone IV E devices; one powered with core voltage VCCINT 1.0 V, and another powered with core voltage VCCINT 1.2 V. Each variant has different ordering codes.
- (22) In Cyclone IV GX devices, the number of optional high speed differential reference clock input for each device density is different.
- (23) If none of the transceivers are used in Cyclone IV GX devices, then you can tie the transceiver power pins VCCL_GXB, VCCH_GXB, and VCCA_GXB to GND. In addition, you can connect RREF0 pin directly to GND.

Cyclone® IV Device Family Pin Connection Guidelines
PCG-01008- 1.2

Example 1. Cyclone IV GX Power Supply Sharing Guidelines

Power Pin Name	Regulator Count	Voltage Level (V)	Supply Tolerance	Power Source	Regulator Switching	Notes
VCCINT	1	1.2	± 40 mV	Switcher	Share	May be able to share VCCD_PLL and VCCL_GXB with VCCINT with proper isolation filters. With proper isolation filter, limit the VCCD_PLL and VCCL_GXB power supplies to ±3% maximum ripple voltage. Depending on the regulator capabilities this supply may be shared with multiple Cyclone IV devices. Use the Early Power Estimation (EPE) tool within Quartus II to assist in determining the power required for your specific design.
VCCD_PLL					Isolate	
VCCL_GXB					Isolate	
VCCIO	2	Varies	± 5 %	Linear or Switcher *	Share if 2.5 V	If VCCIO requires 2.5 V, may be able to share VCCH_GXB, VCCA_GXB, VCCA, and/or VCC_CLKIN with a common 2.5 V supply with proper isolation filters. However, for any other VCCIO voltage you will require a 2.5 V regulator for VCCH_GXB, VCCA_GXB, and VCCA. Use the EPE tool to assist in determining the power required for your specific design.
VCCH_GXB		2.5			Isolate	May be able to share VCCH_GXB and VCCA_GXB with a common 2.5 V supply with a proper isolation filter. With proper isolation filter, limit the VCCH_GXB and VCCA_GXB power supplies to ±3% maximum ripple voltage. Depending on the regulator capabilities, this supply may be shared with multiple Cyclone IV devices. Use the EPE tool to assist in determining the power required for your specific design.
VCCA_GXB					Isolate	VCC_CLKIN must be set to 2.5 V if the CLKIN is used as a transceiver refclk. If VCC_CLKIN requires 2.5 V, may be able to share VCCA with a common 2.5 V supply with a proper isolation filter. However, for any other VCC_CLKIN voltage you will require a 2.5 V regulator for VCCH_GXB, VCCA_GXB, and VCCA. With proper isolation filter, limit the VCCA power supply to ±3% maximum ripple voltage. Depending on the regulator capabilities, this supply may be shared with multiple Cyclone IV devices. Use the EPE tool to assist in determining the power required for your specific design.
VCCA		Varies			Isolate. Share if 2.5 V	
VCC_CLKIN						

Each board design requires its own power analysis to determine the required power regulators needed to satisfy the specific board design requirements. An example block diagram is provided in Figure 1.

Cyclone® IV Device Family Pin Connection Guidelines
PCG-01008- 1.2

Figure 1. Example Cyclone IV GX Power Supplies Block Diagram

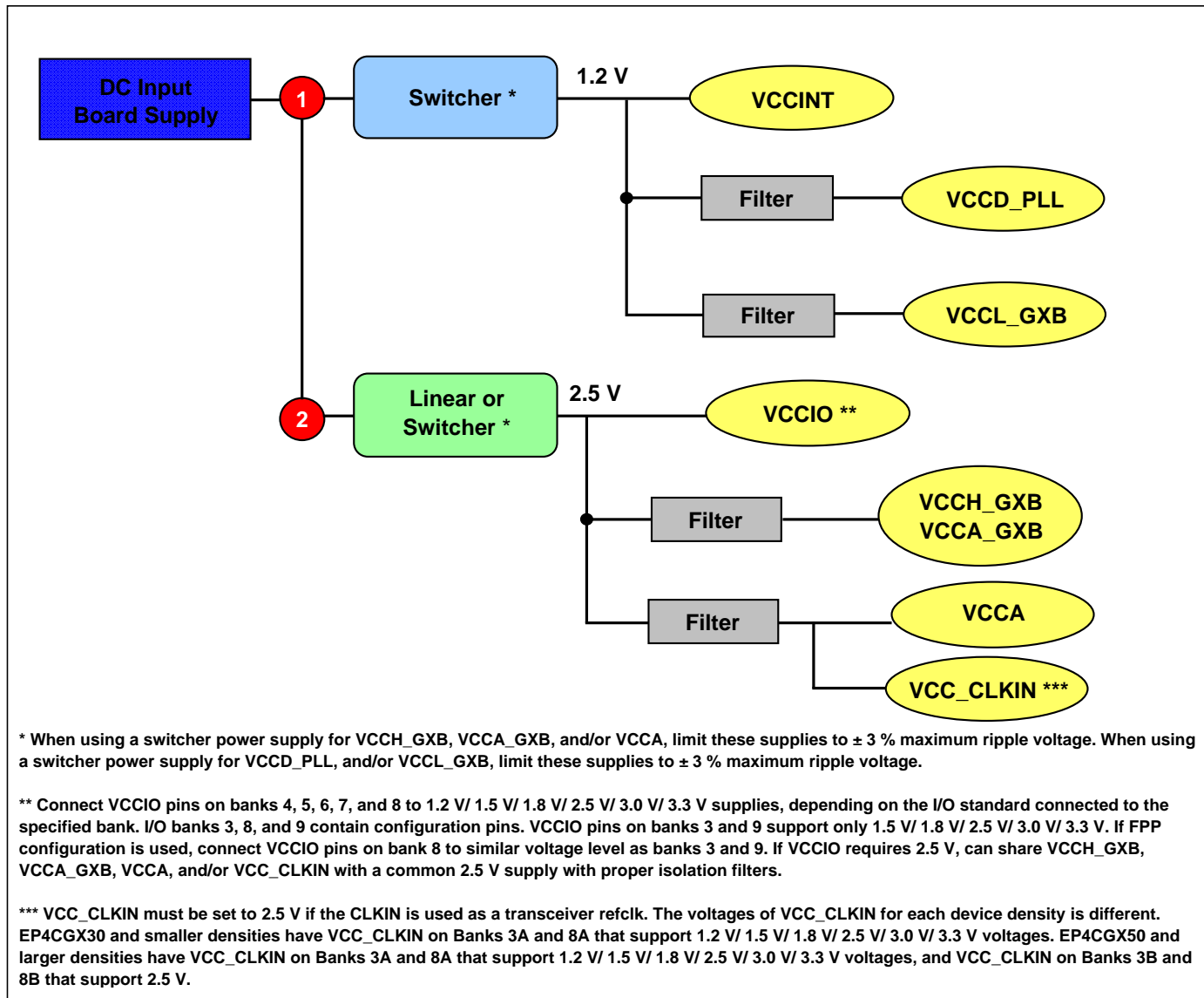

Cyclone® IV Device Family Pin Connection Guidelines
PCG-01008- 1.2

Example 2. Cyclone IV E Power Supply Sharing Guidelines

Power Pin Name	Regulator Count	Voltage Level (V)	Supply Tolerance	Power Source	Regulator Switching	Notes
VCCINT	1	1.0/1.2	± 30 mV/± 50 mV	Switcher	Share	May be able to share VCCD_PLL with VCCINT with a proper isolation filter. With proper isolation filter, limit the VCCD_PLL power supply to ±3% maximum ripple voltage. Depending on the regulator capabilities this supply may be shared with multiple Cyclone IV devices. Use the Early Power Estimation (EPE) tool within Quartus II to assist in determining the power required for your specific design.
VCCD_PLL					Isolate	
VCCIO	2	Varies	± 5 %	Linear or Switcher *	Share if 2.5 V	If VCCIO requires 2.5 V, may be able to share VCCA with a common 2.5 V supply with a proper isolation filter. However, for any other VCCIO voltage you will require a 2.5 V regulator for VCCA. Use the EPE tool to assist in determining the power required for your specific design.
VCCA		2.5			Isolate	

Each board design requires its own power analysis to determine the required power regulators needed to satisfy the specific board design requirements. An example block diagram is provided in Figure 2.

Cyclone® IV Device Family Pin Connection Guidelines
PCG-01008- 1.2

Figure 2. Example Cyclone IV E Power Supplies Block Diagram

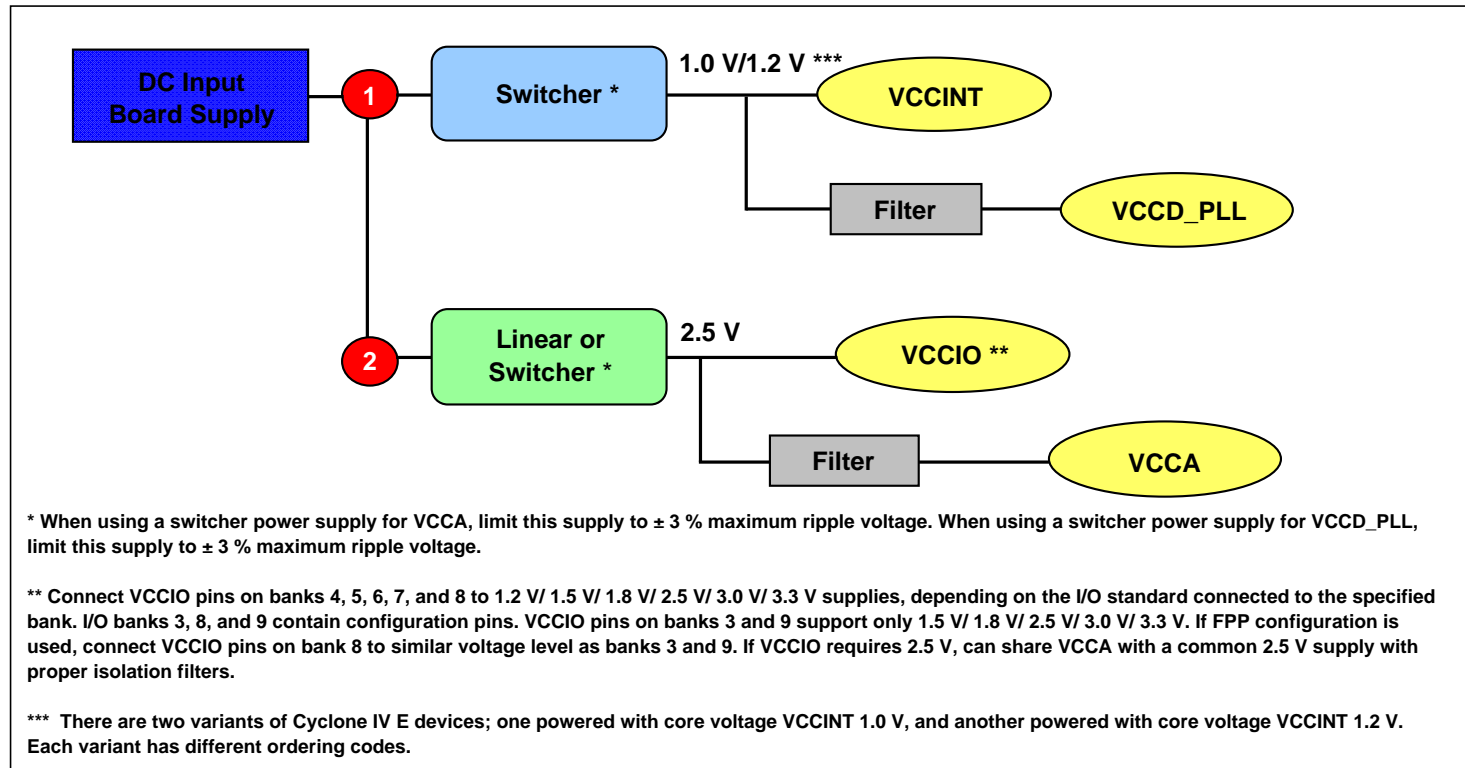

**Cyclone® IV Device Family Pin Connection Guidelines
PCG-01008- 1.2**

Revision History

Revision	Description of Changes	Date
1.0	Initial release.	10/23/2009
1.1	Added column for Cyclone IV E information in Pin Connections Guideline sheet. Added Cyclone IV E sheet.	1/8/2010
1.2	Updated for the Quartus II software 10.0 release.	6/30/2010