

## Introduction

To improve performance and reduce costs, Altera has introduced devices fabricated on an advanced process that requires a 2.5-V power supply. Although 2.5-V devices are new to the programmable logic industry, they are well established in the microprocessor and memory industries.

The high-performance APEX™ 20K and FLEX® 10KE devices accommodate designs that require increased performance and density, while using half the power consumption of 3.3-V devices. MAX® 7000B devices offer the industry's first 2.5-V product-term-based devices with unprecedented pin-to-pin delays as fast as 3.5 ns. Many customers use 5.0- and 3.3-V board designs. To take advantage of low-voltage designs, a voltage regulator is required to lower the voltage supply level to 2.5 V.

Several companies such as Linear Technology Corporation, Maxim Integrated Products, and National Semiconductor Corporation produce voltage regulators for low-voltage devices. This application note provides guidelines for developing boards using Linear Technology's voltage regulators, and covers the following topics:

- Advantages of 2.5-V devices
- Power sequencing and hot-socketing FLEX 10KE devices
- Using MultiVolt™ I/O pins
- Voltage regulators
  - Linear voltage regulators
  - Switching voltage regulators
  - Voltage regulator specifications and terminology
  - Selecting voltage regulators
- 2.5-V regulator circuits
- 2.5-V regulator application examples
- Board layout

## Advantages of 2.5-V Devices

The 2.5-V APEX 20K, FLEX 10KE, and MAX 7000B devices have the following advantages:

- 25% improved performance over 3.3-V FLEX 10K devices
- 40% faster propagation delays for MAX 7000B devices
- 50% lower power consumption than 3.3-V devices
- Improved I/O performance
- Reduced cost
- Lower operating temperatures

- Improved reliability over older devices
- Less need for fans and other temperature-control elements

The 2.5-V FLEX 10KE devices consume approximately 50% less power than 3.3-V FLEX 10KE devices. To illustrate this fact, compare the EPF10K100B and EPF10K100A devices. Using the following equation, you can determine the power consumption ( $P_{ACTIVE}$ ) for both devices. This comparison assumes that both devices use the same design.

$$P_{ACTIVE} = K \times f_{MAX} \times N \times \text{tog}_{LC} \times V_{CC}$$

Because  $f_{MAX}$ ,  $N$ , and  $\text{tog}_{LC}$  are constant, the power consumption difference lies in the change in the  $K$  value and  $V_{CC}$  supply level. [Table 1](#) shows that the EPF10K100B device uses 49.6% less power than the EPF10K100A device.

<b>Table 1. Power Savings Example</b>				
<b>Device</b>	<b>K Value</b>	<b>V<sub>CC</sub> (V)</b>	<b>K × V<sub>CC</sub> (V)</b>	<b>Power Savings</b>
EPF10K100B	19	2.5	47.5	49.6%
EPF10K100A	29	3.3	95.7	

## Power Sequencing & Hot-Socketing FLEX 10KE Devices

Because 2.5-V FLEX 10KE (including the EPF10K100B) devices can be used in a multi-voltage environment, they have been designed specifically to tolerate any possible power-up sequence. Therefore, the  $V_{CCIO}$  (I/O supply voltage) and  $V_{CCINT}$  (internal logic supply) power planes can be powered up in any order.

Boards with these devices support hot-socketing, and thus can be inserted into a live back plane. User I/O and configuration pins can be driven before and during power up without causing contention because the device's I/O pins are tri-stated. Specifically, 2.5-V, 3.3-V, and 5.0-V input signals can drive these devices before  $V_{CCINT}$  or  $V_{CCIO}$  is applied with no special precautions required.

For more information, see [Application Note 107 \(Using Altera Devices in Multiple Voltage Systems\)](#).

## Using MultiVolt I/O Pins

FLEX 10KE devices require a 2.5-V core ( $V_{CCINT}$ ) and a 3.3-V or 2.5-V I/O supply voltage level ( $V_{CCIO}$ ). All pins, including dedicated inputs, clock, I/O, and JTAG pins, are 5.0-V tolerant before and after  $V_{CCINT}$  and  $V_{CCIO}$  are powered.

When  $V_{CCIO}$  is connected to 2.5 V, the output is compatible with 2.5-V logic levels. The output pins can be made 3.3-V or 5.0-V compatible by using open-drain outputs pulled up with external resistors.

When  $V_{CCIO}$  is connected to a 3.3-V power supply, the output is compatible with 3.3-V CMOS and 3.3-V and 5.0-V TTL logic levels. The output pins can be made 5.0-V CMOS compatible by configuring the output pins as open-drain outputs and pulling them up to 5.0-V with external resistors.

**Figure 1. FLEX 10KE Devices Interface with 3.3-V & 5.0-V Devices**

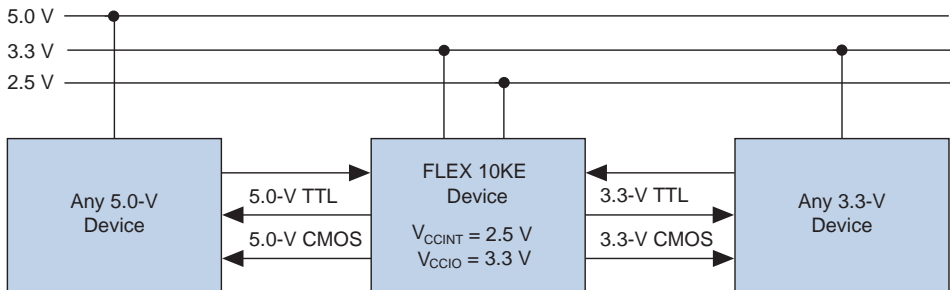

Figure 1 shows that FLEX 10KE devices can interface with 3.3-V and 5.0-V devices while operating on a 2.5-V core voltage to increase performance and save power.

## Voltage Regulators

This section discusses how to generate a 2.5-V supply from another system supply. Supplying power to the 2.5-V core and/or I/O pins requires a 5.0-V or 3.3-V to 2.5-V voltage regulator. The 2.5-V supply can be either a linear or switching voltage regulator. A linear regulator is preferred for low-power applications because it minimizes device count and has acceptable efficiency for most applications. When high efficiency is required, Altera recommends using a switching voltage regulator. Switching regulators are ideal for high-power applications because of their high efficiency.

You can use the following information to help decide which regulator to use in your system, and how to implement the regulator in your design.

### Linear Voltage Regulators

Linear voltage regulators generate a regulated output from a higher magnitude input voltage using current pass elements in a linear mode. Linear regulators are available in two topologies: one using a series pass element and a second using a shunt element like a zener diode. Shunt regulators are very inefficient, and for that reason Altera recommends using series linear regulators.

Series linear regulators (see [Figure 2](#)) regulate the output voltage by using a series pass element (i.e., a bipolar transistor or MOSFET) controlled by a feedback error amplifier, which compares the output to a reference voltage. The error amplifier drives the transistor further on or off continuously to control the flow of current needed to sustain a steady voltage level across the load.

**Figure 2. Series Linear Regulator**

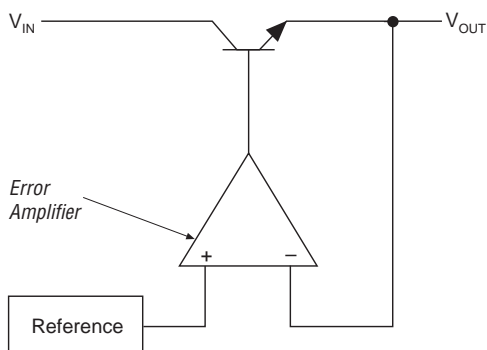

[Table 2](#) shows the advantages and disadvantages of linear regulators.

<b>Table 2. Linear Regulator Advantages &amp; Disadvantages</b>	
<b>Advantages</b>	<b>Disadvantages</b>
<ul style="list-style-type: none"> <li>■ Requires few supporting components</li> <li>■ Low cost</li> <li>■ Requires less board space</li> <li>■ Quick transient response</li> <li>■ Better noise and drift characteristics</li> <li>■ No electromagnetic interference (EMI) radiation from switching components</li> <li>■ Tighter regulation</li> </ul>	<ul style="list-style-type: none"> <li>■ Less efficient (typically 75%)</li> <li>■ Higher power dissipation</li> <li>■ Greater heat sink requirements</li> </ul>

One way to improve the efficiency of linear regulators is to minimize the difference between the input and output voltages. The dropout voltage is the minimum allowable difference between the regulator's input and output voltage. This application note focuses on low dropout voltage (LDO) linear regulators.

Linear regulators are available with fixed, variable, single, or multiple outputs. Linear Technology makes multiple-output regulators that can generate both 3.3-V and 2.5-V levels from a 5.0-V supply. If only a 5.0-V supply is available on the board, multiple-output regulators are useful. The 2.5-V supplies power to the core logic and the 3.3-V supply is required to interface with 3.3-V and 5.0-V devices. Fixed-output regulators have fewer supporting components, reducing board space and cost. [Figure 3](#) shows an example of a three-terminal, fixed-output linear regulator.

**Figure 3. Three-Terminal, Fixed-Output Linear Regulator**

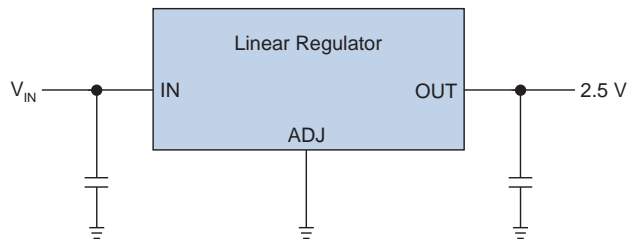

Adjustable-output regulators contain a voltage divider network that controls the regulator's output. [Figure 4](#) shows how a three-terminal linear regulator can also be used in an adjustable-output configuration.

**Figure 4. Adjustable-Output Linear Regulator**

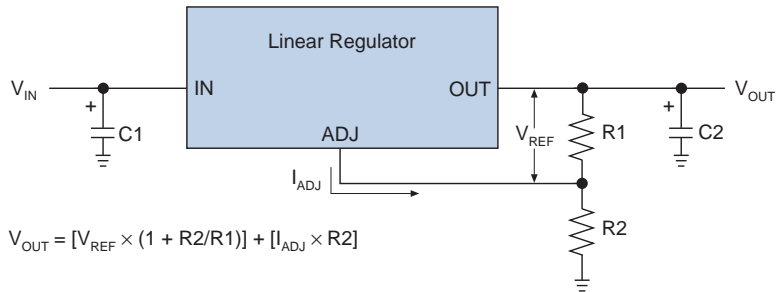

## Switching Voltage Regulators

When designed properly, step-down switching regulators can provide 3.3-V to 2.5-V conversion efficiencies as high as 95%. Keys to high efficiency include minimizing quiescent current, using a low resistance power MOSFET switch, and, in higher current applications, using a synchronous switch to reduce diode losses. In continuous operation, the duty cycle for a 3.3-V to 2.5-V switching regulator is 75%, which means that the switch is on for 75% of each cycle and off for the remaining 25%.

Switching regulators supply power by pulsing the output voltage and current to the load. [Table 3](#) shows the advantages and disadvantages of switching regulators. For more information on switching regulators, refer to *Application Note 35 (Step-Down Switching Regulators)* from Linear Technology.

<b>Table 3. Switching Regulator Advantages &amp; Disadvantages</b>	
<b>Advantages</b>	<b>Disadvantages</b>
<ul style="list-style-type: none"> <li>■ Highly efficient (typically &gt; 80%)</li> <li>■ Reduced power dissipation</li> <li>■ Smaller heat sink requirements</li> <li>■ Wider input voltage range</li> <li>■ High power density</li> </ul>	<ul style="list-style-type: none"> <li>■ Generates EMI</li> <li>■ Complex to design</li> <li>■ Requires 15 or more supporting components</li> <li>■ Higher cost</li> <li>■ Requires more board space</li> </ul>

There are two types of switching regulators: asynchronous and synchronous. Asynchronous switching regulators have one field effect transistor (FET) and a diode to provide the current path while the FET is off (see [Figure 5](#)).

**Figure 5. Asynchronous Switching Regulator**

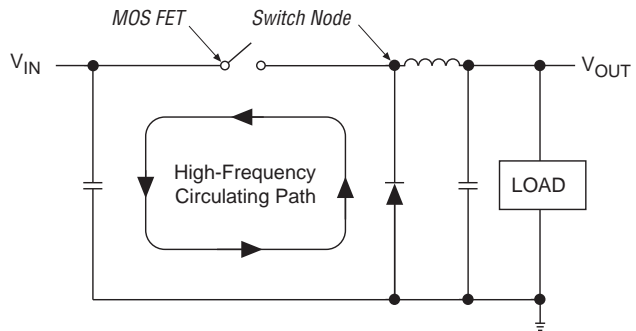

Synchronous switching regulators have a voltage- or current-controlled oscillator that controls the on and off time of the two MOSFET devices that supply the current to the circuit (see [Figure 6](#)).

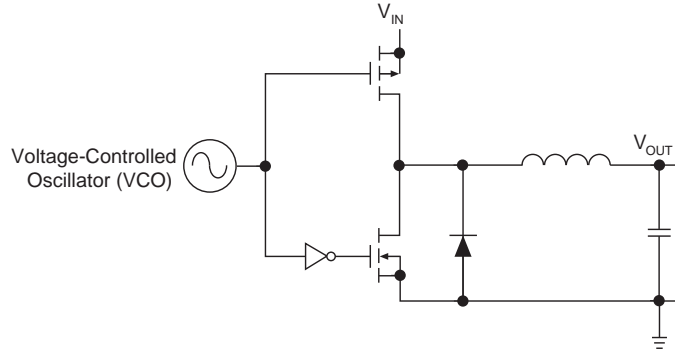
**Figure 6. Voltage-Controlled Synchronous Switching Regulator**

## Voltage Regulator Specifications & Terminology

Table 4 shows the terminology and specifications commonly encountered with voltage regulators. Symbols are shown in parentheses. If the symbols are different for linear and switching regulators, the linear regulator symbol is listed first.

Specification/Terminology	Description
Input Voltage Range ( $V_{IN}$ , $V_{CC}$ )	Minimum and maximum input voltages define the input voltage range, which is determined by the integrated circuit (IC) process voltage capabilities.
Line Regulation (Line Regulation, $\Delta V_{OUT}$ )	Line regulation is the variation of the output voltage with changes in the input voltage. Error amplifier gain, pass transistor gain, and output impedance all influence line regulation. Higher gain results in better regulation. Board layout and IC pin-outs are also important because stray resistances can introduce errors.
Load Regulation (Load Regulation, $\Delta V_{OUT}$ )	Load regulation is a variation in the output voltage caused by changes in the input supply current. Linear Technology regulators are designed to minimize load regulation, which is affected by error amplifier gain, pass transistor gain, and output impedance.
Output Voltage Selection	Output voltage selection is adjustable by resistor voltage divider networks connected to the error amplifier input that control the output voltage. There are multiple output regulators that create 5.0-V, 3.3-V, and 2.5-V supplies.
Quiescent Current	Quiescent current is the supply current during a no-load or “quiescent” state. This current is sometimes used as a general term for a supply current used by the IC.

**Table 4. Voltage Regulator Specifications & Terminology (Part 2 of 2)**

Specification/Terminology	Description
Dropout Voltage	Dropout voltage is the difference between the input and output voltages when the input is low enough to cause the output to drop out of regulation. The dropout voltage should be as low as possible for better efficiency and to obtain regulation from 3.3 V to 2.5 V.
Current Limiting	Voltage regulators are designed to limit the amount of output current in the event of a failing load. A short in the load causes the current voltage and output voltage to decrease. This event cuts power dissipation in the IC during a short circuit.
Thermal Overload Protection	This feature limits power dissipation if the regulator overheats. When a specified temperature is reached, the IC turns off the output drive transistors, allowing the regulator to cool. Normal operation resumes once the regulator reaches a normal operating temperature.
Reverse Current Protection	If the input power supply fails, large output capacitors can cause a substantial reverse current to flow backwards through the IC, potentially causing damage. To prevent damage, protection diodes in the IC create a path for the current to flow from $V_{OUT}$ to $V_{IN}$ .
Stability	The dominant pole placed by the output capacitor influences stability. Voltage regulator vendors can assist you in output capacitor selection for regulator designs that differ from what is offered.
Minimum Load Requirements	A minimum load from the voltage divider network is required for good IC regulation, which also serves as the ground for the IC current path.

## Maximum Output Current

Select an external MOSFET switching transistor (optional) based on the maximum output current that it can supply. Use a MOSFET with a low on-resistance and a voltage rating high enough to avoid avalanche breakdown. For gate-drive voltages less than 9 V, use a logic-level MOSFET. A logic-level MOSFET is required only for topologies with a controller IC and an external MOSFET.

## Voltage Divider Network

Design a voltage divider network if you are using an adjustable output regulator. Follow the instructions in the controller or converter IC's data sheet to adjust the output voltage.

## Selecting Voltage Regulators

Your choice of a voltage regulator is dependent on your design requirements. The key to selecting a voltage regulator is understanding the regulator parameters and how they relate to the design.

The following checklist can assist you in selecting the proper regulator for your design:

- ❑ Do you require both a 3.3-V and 2.5-V output ( $V_{OUT}$ )?
- ❑ What precision is required on the regulated 2.5-V and/or 3.3-V supplies (line and load regulation)?
- ❑ What supply voltages ( $V_{IN}$  or  $V_{CC}$ ) are available on the board?
- ❑ What voltage variance (input voltage range) is expected on  $V_{IN}$  or  $V_{CC}$ ?
- ❑ What is the maximum  $I_{CC}$  ( $I_{OUT}$ ) required by your Altera device?
- ❑ What is the maximum current surge ( $I_{OUT(MAX)}$ ) that the regulator will need to supply instantaneously?

### *Choose a Regulator Type*

If required, select either a linear, asynchronous switching, or synchronous switching regulator based on your output current, regulator efficiency, cost, and board space requirements. DC-to-DC converters have output current capabilities from 1 to 8 A. For higher output current applications, a controller with an external MOSFET, rated for higher current, can be used.

### *Calculate the Maximum Input Current*

The maximum input current—based on the output power requirements at the maximum input voltage—can be estimated using the following equation:

$$I_{IN,DC(MAX)} = \frac{V_{OUT} \times I_{OUT(MAX)}}{\eta \times V_{IN(MAX)}}$$

Where  $\eta$  is nominal efficiency: typically 90% for switching regulators, 75% for linear 3.3-V to 2.5-V conversion, and 50% for linear 5.0-V to 2.5-V conversion.

Once the design requirements have been identified, select the voltage regulator that is best for your design. Table 5 lists Linear Technology regulators at the time this document was printed. Contact Linear Technology for availability. Figure 7 compares Linear Technology output voltage regulators with regard to output current, efficiency, board space, component, and cost requirements.

**Table 5. Linear Technology 2.5-V Output Voltage Regulators**

Voltage Regulator	Regulator Type	Total Number of Components	V <sub>IN</sub> (V)	I <sub>OUT</sub> (A)	Special Features
LT1573	Linear	12	3.3	2	3.3 V to 2.5 V
LT1580CT	Linear	5	5.0, 3.3 (1)	7	Uses fewest devices
LT1584	Linear	5	5.0	7	–
LT1585A	Linear	6	5.0	4.6	–
LT1587	Linear	6	5.0	3	Inexpensive solution
LTC1143L	Switching	29	5.0	2	Dual 3.3-V/2.5-V output
LTC1265	Switching	14	5.0	1	–
LTC1624	Switching	12	5.0	2	Selectable output
LTC1649	Switching	22	3.3	8	3.3 V to 2.5 V

**Note:**  
 (1) Requires a 3.3-V supply to power the regulator and a low current (0.2 A) 5.0-V supply to bias the transistors.

**Figure 7. 2.5-V Voltage Regulators**

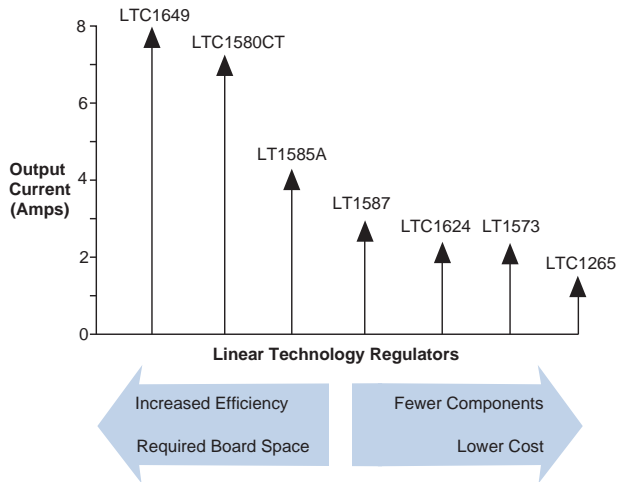



For more information on any of the Linear Technology regulators, contact Linear Technology directly at <http://www.linear.com> or call them at (408) 432-1900.

## 2.5-V Regulator Circuits

This section contains the circuit diagrams for the voltage regulators discussed in this application note.

The LT1573 linear voltage regulator converts 3.3 V to 2.5 V with a maximum output current of 2 A (see Figure 8). You can increase the output current by selecting a pnp transistor ( $Q_{OUT}$ ) with a higher current rating. For more information on the LT1573 linear voltage regulator, contact Linear Technology.

**Figure 8. LT1573: 3.3-V to 2.5-V/2-A Linear Voltage Regulator** Notes (1), (2)

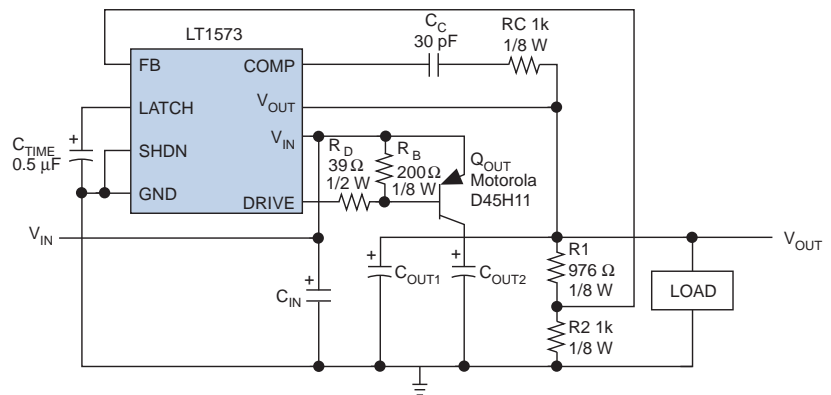

### Notes:

- (1)  $C_{IN}$  = 22  $\mu$ F surface-mount tantalum capacitor.  
 $C_{OUT1}$  = 10  $\mu$ F surface-mount ceramic capacitor.  
 $C_{OUT2}$  = 15  $\mu$ F surface-mount tantalum capacitor.  
 $C_{TIME}$  = 0.5  $\mu$ F for 100 ms time-out at room temperature.
- (2) The SHDN (active high) pin should be tied to ground if it is not used.

Figure 9 shows a one-chip fixed-output 2.5-V linear voltage regulator rated up to 7 A. The 3.3-V power supply is the main source of current for the regulator. The low current 5.0-V supply is used to bias internal power transistors.

**Figure 9. LT1580-2.5: 3.3-V to 2.5-V/7-A Linear Voltage Regulator**

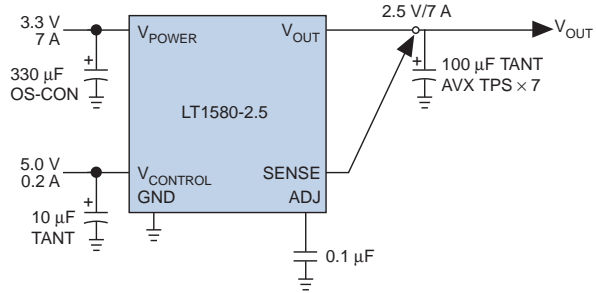

Adjustable 5.0-V to 2.5-V regulators (shown in Figures 10 through 12) cover a 3-A to 7-A range of low-cost, low-device, board-space efficient solutions.

**Figure 10. LT1584: 5.0-V to 2.5-V/7-A Linear Voltage Regulator**

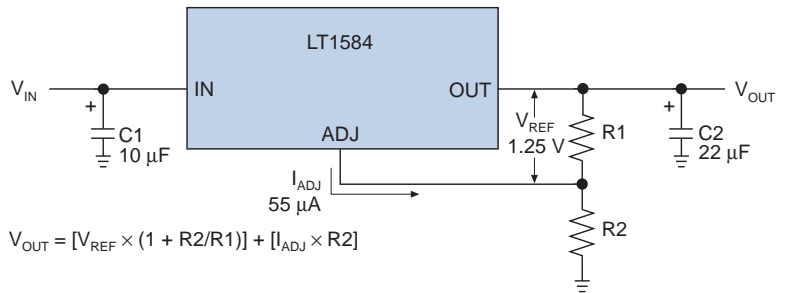

**Figure 11. LT1585A: 5.0-V to 2.5-V/4.6-A Linear Voltage Regulator**

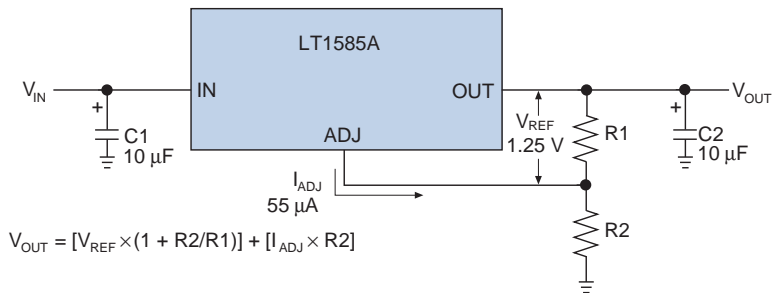
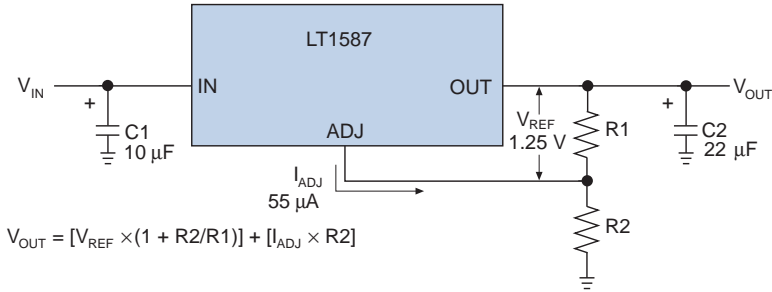

Figure 12. LT1587: 5.0-V to 2.5-V/3-A Linear Voltage Regulator



High-efficiency switching regulators are shown in Figures 13 and 14. The output voltage is controlled by a selectable resistor network. The resistor values have been selected for 2.5-V output operation.

Figure 13. LTC1265: 5.0-V to 2.5-V/1-A Asynchronous Switching Regulator

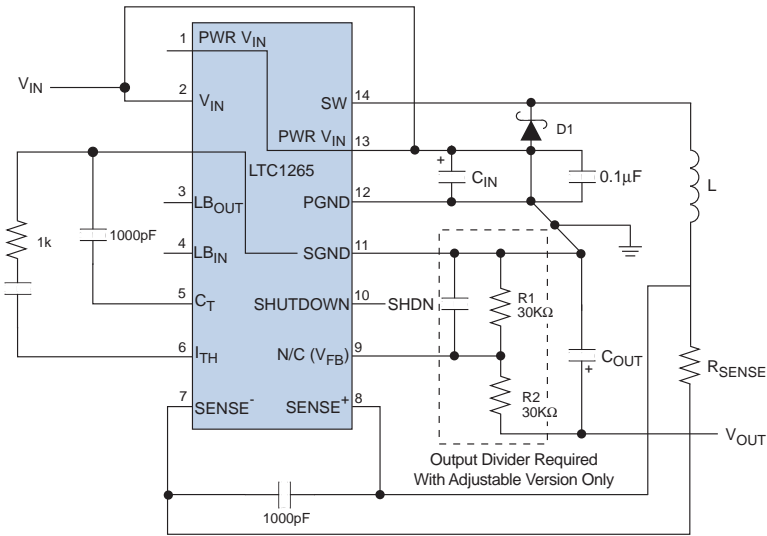

Figure 14. LTC1624: 5.0-V to 2.5-V/2-A Asynchronous Switching Regulator

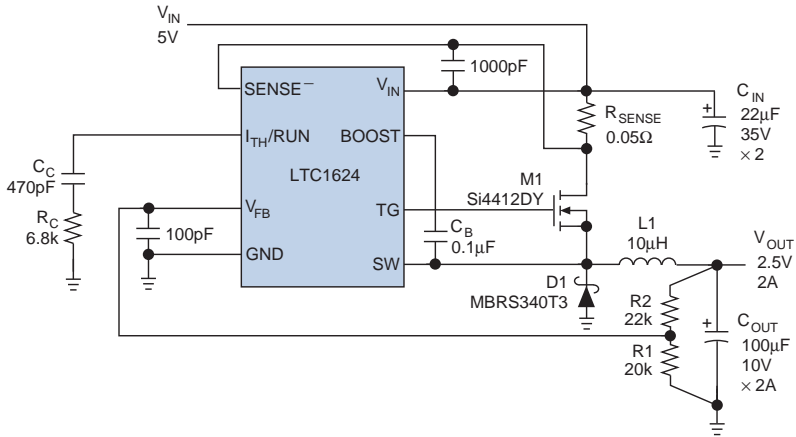

Figure 15 shows a synchronous switching controller with external MOSFETs used for high-current applications.

Figure 15. Synchronous Switching 2.5-V/15-A Regulator

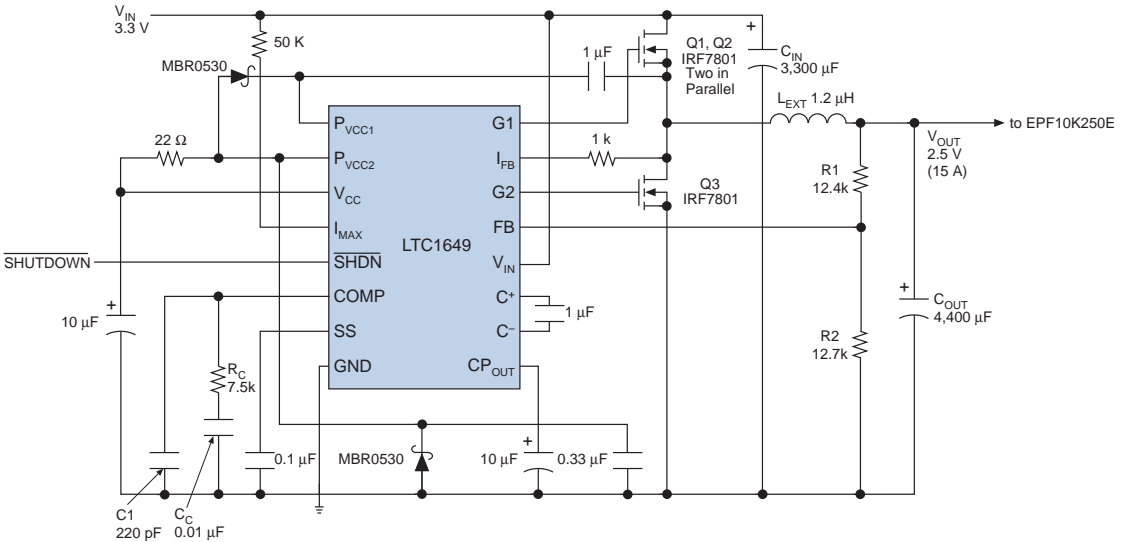
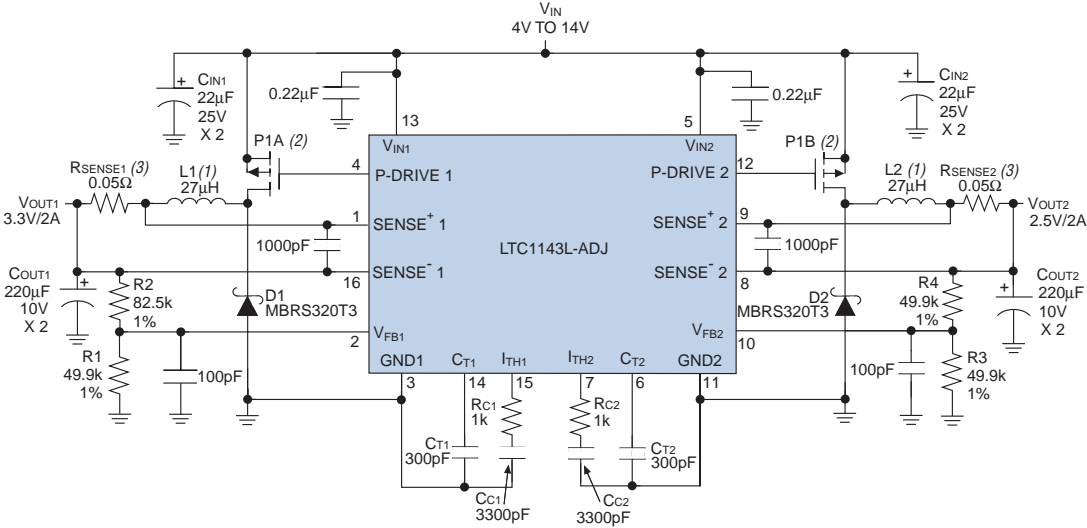

Figure 16 shows the high-efficiency dual-output switching regulator used to generate the 3.3-V and 2.5-V supply.

Figure 16. High Efficiency Dual Output 3.3-V/2.5-V Regulator



Notes:

- (1) L1 and L2 refer to a Sumida CDRH125-270.
- (2) P1 refers to a Siliconix Si4953DY/Fairchild NDS8947.
- (3) R<sub>SENSE1</sub> and R<sub>SENSE2</sub> refer to a Dale WSL-2010-.05.

If you require further assistance using the voltage regulators discussed in this application note, contact Linear Technology.

## 2.5-V Regulator Application Examples

The following sections show the process used to select a voltage regulator for three sample designs.

### 3.3-V to 2.5-V Linear Regulator Example

This example shows the simplest solution available on the market today for converting 3.3 V to 2.5 V. Table 6 shows the design requirements for the EPF10K30EQC208 needed to select a regulator. Figure 17 uses the checklist on page 9 to select a voltage regulator for the EPF10K30EQC208 device.

Design Requirement	Value
Output voltage precision requirement	±5%
Supply voltages available on the board	3.3 V
Voltage supply output current	5 A
Variance of board supply ( $\Delta V_{IN}$ )	±5%
<b>f<sub>MAX</sub></b>	100 MHz
Output pins	120
Average <b>tog<sub>IO</sub></b>	12.5%
Instantaneous <b>tog<sub>IO</sub></b>	25%
Average <b>tog<sub>LC</sub></b>	12.5%
Instantaneous <b>tog<sub>LC</sub></b>	25%
Utilization	100%
V <sub>CCIO</sub> supply level	3.3 V
V <sub>CCINT</sub> supply level	2.5 V
Efficiency	Not a major requirement

Figure 17 is a worksheet used to estimate the design requirements for an EPF10K30EQC208 design.

### Figure 17. Voltage Regulator Selection Process for EPF10K30EQC208 Design

Output voltage requirements	$V_{OUT} = \underline{2.5\text{ V}}$
Supply voltages	$V_{IN}\text{ OR }V_{CC} = \underline{3.3\text{ V}}$
Supply variance from Linear Technology data sheet	Supply variance = $\underline{\pm 5\%}$
Average output current <i>See Application Note 74 (Evaluating Power for Altera Devices)</i>	Output current $I_{OUT} = \underline{497\text{ mA}}$
Maximum instantaneous output current <i>See Application Note 74 (Evaluating Power for Altera Devices)</i> (Use instantaneous values for <b>tog<sub>LC</sub></b> and <b>tog<sub>IO</sub></b> )	$(I_{OUT(MAX)}) = \underline{995\text{ mA}}$
Voltage regulator selection <i>See Linear Technology LTC 1573 data sheet</i>	$\underline{LT1573}$
Nominal efficiency ( $\eta$ )	Nominal efficiency ( $\eta$ ) = $\underline{75\%}$
Line and load regulation Line regulation + load regulation = $(4\text{mV} + 30\text{mV}) / 2.5\text{ V} \times 100\%$	Line and Load Regulation = $\underline{1.4\% < 5\%}$
Minimum input voltage ( $V_{IN(MIN)}$ ) $(V_{IN(MIN)}) = V_{IN}(1 - \Delta V_{IN}) = 3.3\text{V}(1 - .05)$	$(V_{IN(MIN)}) = \underline{3.135\text{ V}}$
Maximum input current $I_{IN, DC(MAX)} = (V_{OUT} \times I_{OUT(MAX)}) / (\eta \times V_{IN(MIN)})$	$I_{IN, DC(MAX)} = \underline{1.05\text{ A} < 5\text{ A}}$

## Synchronous Switching Regulator Example

This design example displays a worst-case scenario for power consumption. Table 7 shows design requirements for a 2.5-V design using an EPF10K250E device. These requirements are unique to this design.

**Table 7. Design Requirements for the Example EPF10K250EBC672 Design**

Design Requirement	Value
Output voltage precision requirement	±5%
Supply voltages available on the board	3.3 V
Voltage supply output current available for this section	8 A
Board supply variance ( $\Delta V_{IN}$ )	±5%
$f_{MAX}$	100 MHz
Output pins	350
Average $tog_{IO}$	12.5%
Instantaneous $tog_{IO}$	20%
Average $tog_{LC}$	12.5%
Instantaneous $tog_{LC}$	20%
Utilization	100%
$V_{CCIO}$ supply level	3.3 V
$V_{CCINT}$ supply level	2.5 V
Efficiency	≥ 90%

Figure 18 uses the checklist on page 9 to help select the appropriate voltage regulator.

**Figure 18. Voltage Regulator Selection Process for EPF10K250EBC672 Design**

Output voltage requirements	$V_{OUT} = \underline{2.5\text{ V}}$
Supply voltages	$V_{IN}\text{ OR }V_{CC} = \underline{3.3\text{ V}}$
Supply variance from Linear Technology data sheet	Supply variance = $\underline{\pm 5\%}$
Average output current <i>See Application Note 74 (Evaluating Power for Altera Devices)</i>	Output current $I_{OUT} = \underline{3.2\text{ A}}$
Maximum instantaneous output current <i>See Application Note 74 (Evaluating Power for Altera Devices)</i> (Use instantaneous values for <b>tog<sub>LC</sub></b> and <b>tog<sub>IO</sub></b> )	$(I_{OUT(MAX)}) = \underline{5.0\text{ A}}$
Voltage regulator selection <i>See Linear Technology LTC 1649 data sheet</i>	$\underline{\text{LTC1649}}$
Nominal efficiency ( $\eta$ )	Nominal efficiency ( $\eta$ ) = $\underline{> 90\%}$
Line and load regulation Line regulation + load regulation = $(4\text{mV} + 30\text{mV}) / 2.5\text{ V} \times 100\%$	Line and Load Regulation = $\underline{1.4\% < 5\%}$
Minimum input voltage ( $V_{IN(MIN)}$ ) $(V_{IN(MIN)}) = V_{IN}(1 - \Delta V_{IN}) = 3.3\text{V}(1 - .05)$	$(V_{IN(MIN)}) = \underline{3.135\text{ V}}$
Maximum input current $I_{IN, DC(MAX)} = (V_{OUT} \times I_{OUT(MAX)}) / (\eta \times V_{IN(MIN)})$	$I_{IN, DC(MAX)} = \underline{4.43\text{ A} < 8.0\text{ A}}$

## Dual Output Regulator Example

Table 8 shows design requirements for a typical 2.5-V customer design using an EPF10K30E device, which is the smallest FLEX 10KE device. These design requirements are unique to this example design.

**Table 8. Design Requirements for the Example EPF10K30EQC208 Design**

<b>Design Requirement</b>	<b>Value</b>
Output voltage precision requirement	±5%
Supply voltages available on the board	5.0 V
Voltage supply output current available for this section	5 A
Variance of board supply ( $\Delta V_{IN}$ )	±5%
$f_{MAX}$	50 MHz
Output pins	105
Average $tog_{IO}$	12.5%
Instantaneous $tog_{IO}$	25%
Average $tog_{LC}$	12.5%
Instantaneous $tog_{LC}$	25%
utilization	100%
$V_{CCIO}$ supply level	3.3 V
$V_{CCINT}$ supply level	2.5 V
Efficiency	Not a major requirement

Figure 9 uses the checklist on page 9 to estimate the design requirements for the EPF10K30EQC208 device.

**Figure 19. Voltage Regulator Selection Process for EPF10K30EQC208 Design**

Output voltage requirements	$V_{OUT} =$ <u>3.3 V and 2.5 V</u>
Supply voltages	$V_{IN}$ OR $V_{CC} =$ <u>5.0 V</u>
Supply variance from Linear Technology data sheet	Supply variance = <u>±5%</u>
Average output current <i>See Application Note 74 (Evaluating Power for Altera Devices)</i>	Output current $I_{OUT} =$ <u>253 mA</u>
Maximum instantaneous output current <i>See Application Note 74 (Evaluating Power for Altera Devices)</i> (Use instantaneous values for $t_{OGLC}$ and $t_{OIG}$ )	$(I_{OUT(MAX)}) =$ <u>496 mA</u>
Voltage regulator selection <i>See Linear Technology LTC 1573 data sheet</i>	<u>LTC1143</u>
Nominal efficiency ( $\eta$ )	Nominal efficiency ( $\eta$ ) = <u>90%</u>
Line and load regulation Line regulation + load regulation = $(4mV + 30mV) / 2.5 V \times 100\%$	Line and Load Regulation = <u>1.4% &lt; 5%</u>
Minimum input voltage ( $V_{IN(MIN)}$ ) $(V_{IN(MIN)}) = V_{IN}(1 - \Delta V_{IN}) = 3.3V(1 - .05)$	$(V_{IN(MIN)}) =$ <u>4.75 V</u>
Maximum input current $I_{IN, DC(MAX)} = (V_{OUT} \times I_{OUT(MAX)}) / (\eta \times V_{IN(MIN)})$	$I_{IN, DC(MAX)} =$ <u>290 mA &lt; 5 A</u>

## Board Layout

Printed circuit board (PCB) layout is extremely important in high-frequency ( $\geq 100$  kHz) switching regulator designs. Poor PCB layout results in increased EMI and ground bounce, which affects the reliability of the voltage regulator by obscuring important voltage and current feedback signals. Altera recommends using Gerber files—pre-designed layouts—supplied by the regulator vendor for your board layout.

If the supplied layouts cannot be used, contact Altera Applications or the regulator vendor for help on re-designing the board to fit your design requirements, while maintaining the proper functionality.

Altera recommends that you use separate layers (if applicable) for signals, the ground plane, the 2.5-V plane, the 3.3-V plane, and the 5.0-V plane. You can support separate layers by using six-layer PCBs, assuming you are using two signal layers. Six-layer boards are inexpensive and easy to manufacture. [Figure 20](#) shows how you can minimize board space by using a single regulator to generate the 3.3-V and 2.5-V supplies from the 5.0-V power supply.

**Figure 20. Single Regulator Solution for Systems that Require 5.0-V, 3.3-V & 2.5-V Supply Levels**

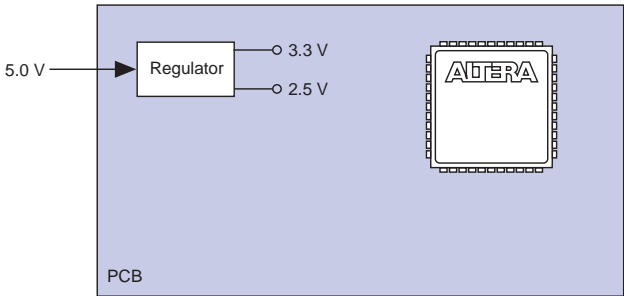

The same regulator can be laid-out using a split-plane method (see [Figure 21](#)). This layout saves one plane by combining the 5.0-V and 2.5-V plane. The layout for this method is structured as follows:

- One 3.3-V plane, covering the entire board
- One plane split between 5.0 V and 2.5 V

This technique assumes that the majority of devices are 3.3 V. Other regulators are possible. To support MultiVolt I/O, Altera devices must have access to 2.5-V and 3.3-V planes.

**Figure 21. Split Board Layout for 3.3-V Systems With 5.0-V & 2.5-V Devices**

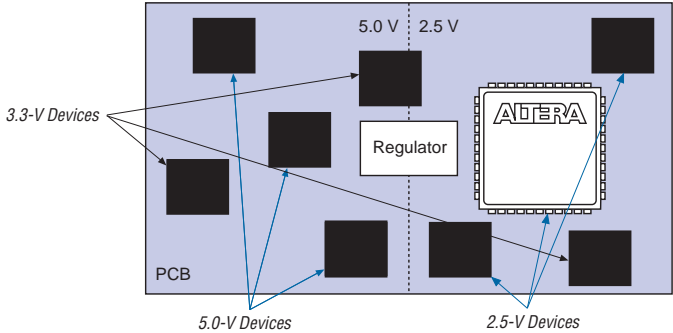

## Conclusion

To accommodate designs with increased performance and density, the high-performance FLEX 10KE devices are built on an advanced, 0.25- $\mu\text{m}$  process while benefiting from half the power consumption of 0.35- $\mu\text{m}$  devices. The MAX 7000B family will offer the industry's first 2.5-V product-term-based devices with pin-to-pin delays as fast as 3.5 ns. APEX 20K devices combine look-up table (LUT), product term (PTERM), and RAM based architectures to offer densities up to two million gates.

FLEX 10KE and MAX 7000B devices offer improved I/O performance, reduced cost, lower operating temperatures, increased reliability, and 50% less power consumption over 3.3-V devices.

## References

Linear Technology Corporation. *Application Note 35 (Step-Down Switching Regulators)*. Milpitas: Linear Technology Corporation, 1989.

Linear Technology Corporation. *LT1573 Data Sheet (Low Dropout Regulator Driver)*. Milpitas: Linear Technology Corporation, 1997.

Linear Technology Corporation. *LT1580/LT1580-2.5 Data Sheet (7 A, Very Low Dropout Regulator Driver)*. Milpitas: Linear Technology Corporation, 1995.

Linear Technology Corporation. *LT1585A/LT1585A-3.3 Data Sheet (5 A Low Dropout Fast Response Positive Regulators Adjustable and Fixed)*. Milpitas: Linear Technology Corporation, 1995.

Linear Technology Corporation. *LT1584/LT1585/LT1587 Data Sheet (7 A, 4.6 A, 3 A Low Dropout Fast Response Positive Regulators Adjustable and Fixed)*. Milpitas: Linear Technology Corporation, 1995.

Linear Technology Corporation. *LTC1143/LTC1143L/LTC1143-ADJ Data Sheet (Dual High Efficiency SO-16 Step-Down Switching Regulator Controllers)*. Milpitas: Linear Technology Corporation, 1994.

Linear Technology Corporation. *LTC1265/LTC1265-3.3/LTC1265-5 Data Sheet (1.2 A, High Efficiency Step-Down DC/DC Converter)*. Milpitas: Linear Technology Corporation, 1995.

Linear Technology Corporation. *LTC1624 Data Sheet (High Efficiency SO-8 N-Channel Switching Regulator Controller)*. Milpitas: Linear Technology Corporation, 1997.

Linear Technology Corporation. *LTC1649 Data Sheet (3.3 V Input High Power Step-Down Switching Regulator Controller)*. Milpitas: Linear Technology Corporation, 1998.

## Revision History

The information contained in *AN 106 (Designing with 2.5-V Devices)* version 1.01 supersedes information published in previous versions. Version 1.01 contains updates to [Figures 5, 7, 16, 17, and 19](#).



101 Innovation Drive  
San Jose, CA 95134  
(408) 544-7000  
<http://www.altera.com>  
**Applications Hotline:**  
(800) 800-EPLD  
**Customer Marketing:**  
(408) 544-7104  
**Literature Services:**  
(888) 3-ALTERA  
[lit\\_req@altera.com](mailto:lit_req@altera.com)

Altera, APEX, FLEX, MAX, FLEX 10K, FLEX 10KE, MAX 7000B, MultiVolt, EPF10K30E, EPF10K100A, EPF10K100B, and EPF10K250E are trademarks and/or service marks of Altera Corporation in the United States and other countries. Altera acknowledges the trademarks of other organizations for their respective products or services mentioned in this document, specifically: LTC and LT are registered trademarks of Linear Technology. Altera products are protected under numerous U.S. and foreign patents and pending applications, maskwork rights, and copyrights. Altera warrants performance of its semiconductor products to current specifications in accordance with Altera's standard warranty, but reserves the right to make changes to any products and services at any time without notice. Altera assumes no responsibility or liability arising out of the application or use of any information, product, or service described herein except as expressly agreed to in writing by Altera Corporation. Altera customers are advised to obtain the latest version of device specifications before relying on any published information and before placing orders for products or services.

Copyright © 1999 Altera Corporation. All rights reserved.



I.S. EN ISO 9001